



HANDBOOK
ON
FIELD OF PLAY
AND
SPECIFICATIONS FOR
SPORTS INFRASTRUCTURE
AT
SAI CENTRES

HANDBOOK
ON
FIELD OF PLAY
AND
SPECIFICATIONS FOR
SPORTS INFRASTRUCTURE
AT
SAI CENTRES

CONTENTS

	Description	Page No.
	FOREWORD	4
	PREFACE	5
1	HOCKEY Field of Play Selection of Turf Type Recommendations for SAI Centers / Academic Institutions Check list for the installation of Synthetic Hockey turf	6 – 20
2	ATHLETIC TRACK Types of Certificates Competition area Types of Competitions Facilities Recommendations for SAI Centers / Academic Institutions. Check list for installation of Synthetic athletic track	21 - 55
3	FOOTBALL Field of Play Recommended dimension Artificial Football Turf Natural Grass Football turf	56 - 79
4	LAWN TENNIS Rules of Tennis/Field of Play Specifications of surfaces Types of Court Surfaces Recommended Specifications for SAI Centers	80 - 89
5	VOLLEYBALL Field of Play Specifications for Volleyball court for SAI Centers	90 – 97
6	HANDBALL Field of Play Specification for Handball Court for SAI Centers	98 - 105
7	BASKETBALL Field of Play, Court and equipment Specification for Basketball Court for SAI Centers	106 - 113
8	BADMINTON Field of Play Specification for International Standard Facilities Specification of flooring for Badminton Court for SAI Centers	114 - 119
9	SWIMMING POOL General Specifications for swimming pools. Recommendations for SAI Centres/Academic Institutions	120 - 131
10	MULTIPURPOSE HALL Four Court Hall Six Court Hall Eight Court Hall Nine Court Hall Twelve Court Hall	132 - 147
11	SQUASH Field of Play Court Dimensions	148 - 165
12	ARTIFICIAL SPORTS LIGHTING Introduction Recommendations for Lux required	166 – 185
20	REFERENCES	186

FOREWORD

1. Sports Authority of India (SAI) has presence across India. It provides training facilities to athletes right from the grass-root level through to the elite level. It is observed that there is a tendency of creating sports infrastructure facilities of the highest international standards irrespective of the level of athlete / training for which it is intended. This not only increases the initial cost but also leads to higher operations and maintenance cost.

2. It is necessary to understand that each International Sports Federation prescribes specifications for the Field of Play depending upon the level of competitions; the standards are higher for global level as compared to national level and still lower for sub-national level. The “Lux” of artificial lighting, the height of Indoor hall etc. can be lowered; the specifications of infrastructure facilities can also be lowered for training purpose and the ‘Run offs’ can be reduced for the sports discipline, which in turn reduces the area required for the Field of Play.

3. During my visit to various SAI centers across the country, it was observed that often coaches and administrators were not fully aware of Field of Play specifications. This handbook aims to serve as a ready reckoner on Field of Play specifications for different sport disciplines.

4. The instant compilation covers major sports played in India. The combat sports have not yet been included. **Subsequently, endeavors will be made to cover field of play of remaining sport disciplines and also cover specifications of equipment used in various sport disciplines.**

5. Though all efforts have been made to ensure the correctness of the information, however, since this is the first publication, any shortcoming may be informed to SAI through e-mail at infradivisionsai@gmail.com.

6. Director / SE (Infrastructure) of Sports Authority of India has compiled the proposed specifications for SAI Regional Centres, Academic Institutions, STCs and SAGs after studying the norms prescribed by respective International Sports Federation. I sincerely hope that the publication serves the purpose for which it has been prepared.

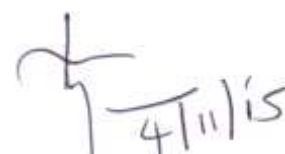

INJETI SRINIVAS, IAS
Director General
Sports Authority of India

PREFACE

SAI has presence PAN India. SAI centers are located in urban/rural areas and remote locations all across India, and have trainees of all stature right from novice to elite level training in SAI facilities.

It is observed that SAI centers/construction agencies are creating infrastructure with very high specifications in an arbitrary manner, irrespective of the stature of trainees who will be using these facilities. This, has resulted in higher infrastructure cost and at times the approved cost has also exceeded. Moreover, the annual maintenance cost is also high.

We tend to create infrastructures of international standards despite the fact that the facilities shall not be used even by National campers or elite athletes. The guidelines or rules on Field of Play from International Federations on respective sports discipline are intended to provide the best possible environment for competitions ***at international level and training for these international competitions.*** These Rules are not intended to govern issues related to the general public or training at grass root or even at community level.

The space required for most games depends on the standard of play; generally the higher the standard the larger the space. The playing areas are usually the same size but increased safety margins/run offs and clear height may be required for international events.. For most competition play an extra zone is required for team benches and an officials' table and a further security zone between teams and spectators may be required for major events. Adding these margins around the playing area produces the critical overall space. However these additional margins are not required for SAI Training Centres. The minimum safe area for each standard of sportsactivities undertaken by the young trainees at our SAI Training Centers is much less than what is required for international competitions.

In view of the above, it is considered necessary to streamline the specifications to be provided for infrastructure facilities and compile guidelines on field of plays notified by respective international federations for various SAI centers/STC/SAG, all over India.



SANJIV BARANWAL, IDSE
Director/SE Infrastructure
Sports Authority of India

FEDERATION OF INTERNATIONAL HOCKEY (FIH)



HOCKEY

1 HOCKEY

1.1 Field of play (Compiled from FIH Handbook)

The information below provides a simplified description of the field of play.

- The field of play is rectangular, 91.40 metres long and 55.00 metres wide.
- Side-lines mark the longer perimeters of the field
- Backlines mark the shorter perimeters of the field.
- The goal-lines are the parts of the back-lines between the goal-posts.
- A centre-line is marked across the middle of the field.
- Lines known as 23 metres lines are marked across the field 22.90 metres from each back-line.
- Areas referred to as the circles are marked inside the field around the goals and opposite the centres of the backlines.
- Penalty spots 150 mm in diameter are marked in front of the centre of each goal with the centre of each spot 6.40 metres from the inner edge of the goal-line.
- All lines are 75 mm wide and are part of the field of play.
- Flag-posts between 1.20 and 1.50 metres in height are placed at each corner of the field.
- Goals are positioned outside the field of play at the centre of and touching each back-line.
- Broken lines are marked with their outer edges 5 meters from the outer edge of each circle-line; *These broken lines became mandatory for international matches with effect from 1 June 2000. Their adoption for other matches is at the discretion of National Associations*
- The playing surface must continue (to create “run-off” areas) for a minimum of 2 metres at the back-lines and 1 metre at the side-lines with an additional unobstructed 1 metre in each case (that is, a total of 3 metres at the ends and 2 metres at the sides of the field). These are minimum requirements with the respective recommended areas being 3 plus 2 metres and 2 plus 1 metres (that is, a total of 5 metres at the ends and 3 metres at the sides of the field).

Note: These unobstructed areas may be surfaced with material different to the synthetic playing surface and may accommodate structures and/or fittings such as drain covers or covered reticulation channels.

Figure 1: Field of Play (compiled from FIH Rule Handbook)

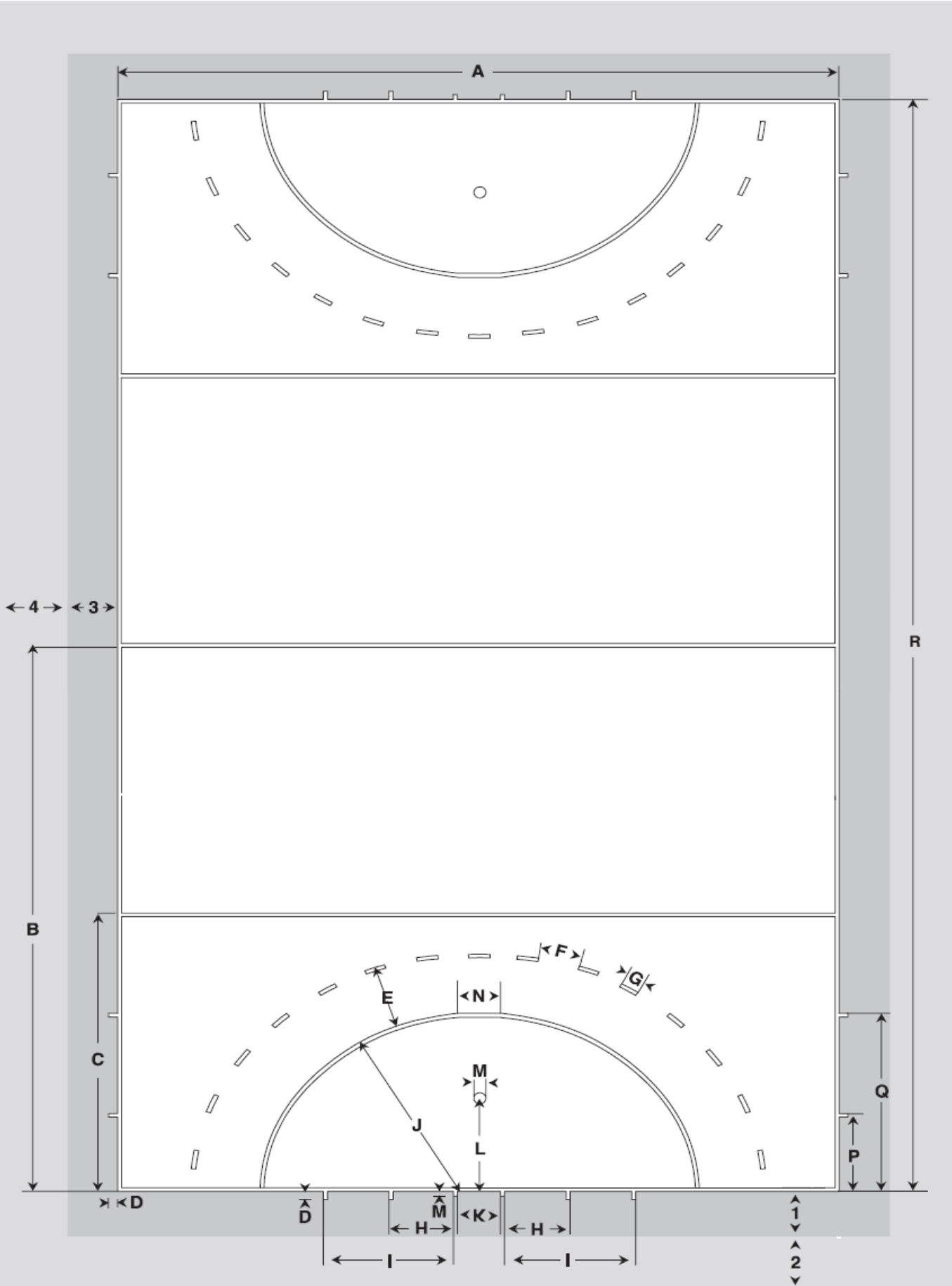

Field Dimensions

Code	Metres	Code	Metres
A	55.00	M	0.15
B	45.70	N	3.66
C	22.90	P	5.00
D	0.30	Q	14.63
E	5.00	R	91.40
F	3.00	1	minimum 2.00
G	0.30	2	1.00
H*	4.975*	(1 + 2)	minimum 3.00
I*	9.975*	3	minimum 1.00
J	14.63	4	1.00
K	3.66	(3 + 4)	minimum 2.00
L	6.475		

** Dimensions H and I are measured from the goal-post line and not from the goal-post itself; the dimensions from the goal-post are 5.00 metres and 10.00 metres respectively.*

1.2 Pitch Orientation: To create the minimum of dazzle from the setting sun, the FIH recommends that pitches be orientated as close as possible north-south. At latitudes further from the equator, the orientation can swing to up to 15° east or west of north-south.

1.3 Pitch Classification: FIH has a classification system for synthetic pitches which fall into two categories: **Global and National**. (Until April 2008, the National category was called “Standard” and this terminology will still appear in some publications.)

The classification is based on a series of pitch performance requirements including the behaviour of a hockey ball and drainage characteristics tested under carefully controlled conditions on the finished pitch surface.

1.3.1 Global Category: Global category pitches are mandatory for all FIH world-level competitions and qualifying tournaments such as:

- Olympic Games
- World Cups
- Junior World Cups
- Champions' Trophies
- Champions' Challenges
- FIH Olympic Games Qualifying Tournaments
- FIH World Cup Qualifying Tournaments

A global category pitch is also sometimes specified in continental or national tournament regulations.

If it is not proposed to host one of the above events, it is not necessary to incur the additional costs to achieve global category standards.

1.3.2 National Category: National category pitches are satisfactory for international matches and/or tournaments other than those referred to above.

1.4 Selection of Turf Type: The level of hockey that is proposed for the venue will be a major influence on the type of pitch surface to be laid. There are essentially two main groups of pitch surface: natural grass and synthetic turf.

1.4.1 Natural Grass Pitches: There are many types of grass, and expert advice should be sought to help in the choice of grass that is most suitable for a particular climate and soil conditions. Similarly, advice on whether to seed the pitch or to lay sods should be sought. The latter is far more expensive, but has the advantage that it can be played on much sooner than a seeded area, which could require at least a year of careful maintenance to become sufficiently established to permit safe play without causing serious damage to the surface.

1.4.2 Synthetic (or Artificial) Turf Pitches There are a number of different types of synthetic surface available. However the surfaces proposed to be used in SAI Centres are considered here. This fall generally undergone of the following headings:

1.4.3 Filled surface: a surface (or carpet) comprising a synthetic yarn filled with sand (or similar material) to the full height of the pile to help maintain its verticality. The pile height is greatest in this type of surface. The sand is an important element. A high quality material with well-rounded particles that allows adequate drainage at all times and prevents compaction of the fill while under use is usually specified by the pitch supplier.

A filled pitch rarely justifies the installation of a watering system. In moderate climates, the sand within the turf carpet can remain slightly damp for much of the time. However, in warmer climates, the pitch will dry out and some degree of watering will greatly improve its playing characteristics. Hence, provision of some form of irrigation (even hand-held hoses) should be seriously contemplated.



1.4.4 Water-based unfilled surface: a surface (or carpet) comprising a very dense synthetic pile of short length. It is essential from the safety, comfort and playability points of view that this type of surface is maintained wet during play. It also ensures that wear on the turf carpet is minimised and the full expected life of the turf realised.



1.5 Pitch Irrigation or Watering

1.5.1 Sand-filled pitch: in most instances, such a pitch does not justify the expense of installing a watering system. However, it is widely known that the pitch plays better when the sand is slightly damp. Consideration should be given, therefore, to the installation of a water source to enable hand-held hose watering to be carried out. This is more important in hotter, drier parts of the world as the sand will certainly dry out and tend to become “dust”. Watering will also improve the playing characteristics.

In more moderate climates, the sand remains damp for longer periods, so the need for such watering will be significantly less.

1.5.2 Water-based unfilled pitch: it is considered essential that this type of pitch is watered for every match. In fact, the FIH strongly discourages playing on an inadequately watered unfilled pitch. There are four main reasons for this:

- greater risk of injury to players;
- the playability of the pitch is affected: the ball does not travel truly and is more likely to bounce dangerously;
- greater wear is caused to the pitch surface, considerably shortening the life of the turf, and could affect the manufacturer's warranty;
- Pitch surface temperatures, particularly in hot climates, can rise to unhealthy levels.

1.6 Pitch Carpet Materials (Yarns)

Historically, turf yarns have been made from nylon, polypropylene or polyethylene, or a combination of those. There are some differences in performance characteristics between them and these are discussed below. The FIH does not specify any one type of yarn; its technical requirements are purely performance based,

None of the yarn material is completely UV-resistant, but polypropylene is probably the best of the three, followed by polyethylene. So for hot, sunny climates, either of these two yarns may be considered.

The majority of FIH approved manufacturers appears to be moving from polypropylene to polyethylene yarns because the latter have an improved slide factor, which in turn requires the application of less water. This indicates that substantial savings in water quantity for irrigation can be realised without any consequential adverse effects on pitch playability or player comfort and safety

1.7 Carpet Manufacture

FIH makes no recommendation with regard to the various treatments to the yarn or the processes to form the turf carpet. For example, the yarn may be twisted, curled, fibrillated, multiplied or have other treatments before it is looped or knitted into a pre-formed backing fabricant then cut to the desired length. The backing fabric is then sealed. Manufacture is by weaving, tufting or knitting to the density required for the particular type of surface.

1.8 Shock-pads: Shock pad is the resilient material under the synthetic turf carpet designed to absorb kinetic energy. Sometimes referred to as 'Shock Absorbing Layer', 'Elastic Layer' or 'E-Layer'. Early synthetic turfs were laid without a shock-pad. It is now recommended that all synthetic pitches be laid with shock-pad as it will help to absorb the impact (dynamic forces) of players running on the surface and reduce the incidence of lower limb injuries. In fact, the FIH now makes a shock-pad mandatory for any pitch to become classified under its listing. It is recommended to provide **In-situ pad**, as this is manufactured on site using a hot mix of rubber shred or crumbs, bound with polyurethane. It is laid using a highway paving machine. The advantage of this system is that the pad can be of variable thickness to even out any imperfections in the level of the underlying base, and can produce a smooth finish on which to lay the turf carpet.

It is recommended that the pitch surface and shock-pad be laid on a properly designed and engineered base and, where necessary, a sub-base. The base should comprise a layer of graded stone (which includes the drainage system) overlain by a layer (preferably two layers) of bituminous material. Carried out properly, the base will outlast by several times the life of the shock-pad and surface carpet.

PERFORMANCE REQUIREMENT OF SYNTHETIC TURF (PRODUCT)

Performance Requirements	Global Turf Product	National Turf Product
Composition	In accordance with manufacturer's product declaration	
Unfilled / Filled	Unfilled	Unfilled / filled
FIH Standard Wet Tests	Yes	Yes
Manufacturer's Reduced Watering Wet Tests	Optional	Optional
Dry tests	Optional	Yes, if designed to be used in dry conditions

Performance Tests

Ball rebound	mean 100 mm to 400 mm individual tests $< \pm 10\%$ from mean	mean 100 mm to 400 mm individual tests $< \pm 20\%$ from mean
Ball roll	mean ≥ 10 m individual tests for either roll or deviation $< \pm 10\%$ from mean	mean ≥ 8 m individual tests for either roll or deviation $< \pm 20\%$ from mean
Ball roll deviation	deviation $\leq 3^\circ$	deviation $\leq 3^\circ$
Underfoot friction	Leroux Pendulum coefficient of friction 0.6 to 1.0 individual tests $< \pm 0.1$ from mean	coefficient of friction 0.6 to 1.0 individual tests $< \pm 0.2$ from mean
	Rotational Resistance 25 – 45 Nm individual tests $< \pm 3$ from mean	25 – 45 Nm individual tests $< \pm 3$ from mean
Impact response	40 to 60 % individual tests $< \pm 5\%$ from mean	40 to 65 % individual tests $< \pm 5\%$ from mean
Pile / pad deformation	$\geq 40\%$ individual tests $< \pm 2\%$ from mean	$\geq 40\%$ individual tests $< \pm 2\%$ from mean
Loss of velocity <i>(test for data collection only)</i>	$< 9\%$	$\geq 9\%$

PERFORMANCE REQUIREMENT OF SYNTHETIC TURF (INSTALLED PITCH)

Performance Requirements		Global Pitch	National Pitch
Product compliance with manufacturer's declaration		Yes	Yes
Ball rebound		mean 100 mm to 400 mm individual test positions < $\pm 10\%$ from mean	mean 100 mm to 400 mm individual test positions < $\pm 20\%$ from mean
Ball roll		mean ≥ 10 m individual tests < $\pm 10\%$ from mean	mean ≥ 8 m individual tests < $\pm 20\%$ from mean
Ball roll deviation		$\leq 3^\circ$	$\leq 3^\circ$
Underfoot friction	Leroux Pendulum	coefficient of friction 0.6 to 1.0 individual tests < ± 0.1 from mean	coefficient of friction 0.6 to 1.0 individual tests < ± 0.2 from mean
	Rotational Resistance	25 – 45 Nm individual tests < ± 3 from mean	25 – 45 Nm individual tests < ± 3 from mean
Impact response		40 to 60 % individual tests < ± 5 % from mean	40 to 65 % individual tests < ± 5 % from mean
Pitch dimensions and markings		line length ± 50 mm line width ± 10 mm circle radius ± 30 mm penalty spots position ± 30 mm length of 300 mm marks ± 30 mm diagonals < 300 mm difference	
Pitch run-offs (minima)		back-line 2 m same synthetic turf surface side-line 1 m same synthetic turf surface both plus 1 m synthetic turf or alternative surface	

Performance Requirements	Global Pitch	National Pitch
Pitch slope	longitudinal fall < 0.2 %	longitudinal fall < 1.0 %
Pitch profile	lateral fall < 0.4 % exceptions < 1.0 % permitted on FIH approval	lateral fall < 1.0 %
Pitch smoothness	deviation ≤ 6 mm above or below 3 m straight edge	
	deviation above or below 300 mm straight edge ≤ 2 mm	≤ 3 mm
Pitch watering	as specified by turf manufacturer	if specified by turf manufacturer
Pitch permeability	≥ 150 mm per hour	≥ 150 mm per hour
Colour	FIH approved	FIH approved
Artificial lighting	<i>See FIH Guide to the Artificial Lighting of Hockey Pitches</i>	<i>See FIH Guide to the Artificial Lighting of Hockey Pitches</i>

Recommendations

- ❖ **Global Category Turf (water based)** is recommended to be used in
 - Regional Centers /Academic Institution
 - STCs/SAGs where the synthetic turf is used by National Campers/Elite Trainees (with the approval of DG SAI)
- ❖ **National Category Turf (Non water based)** is recommended to be used in all other locations
- ❖ **Grass Turf** : is recommended to be used in remote SAI Centers and other STCs/SAGs where synthetic turf could not be laid due to budget constraint

Note:

- ❖ Preferred Synthetic turf yarns are polypropylene or polyethylene.
- ❖ The turf carpet can be made in various ways but the product must be approved by FIH.

- ❖ The shock-pad can be constructed in various ways, but an in-situ pad is generally preferred.
- ❖ Automatic single key operated pop up sprinkler system recommended with similar specifications as installed in MDCN Stadium
- ❖ The relative costing is as under:
 - **Sand-filled Turf (National Category)** is about 20% cheaper than Water-based un-filled Turf (Global Category) and does not require a sprinkler system
 - **Grass Turf** is about 80% cheaper than Global category turf

The 'Run off' beyond side lines and back line should be provided as under:

- **Run off beyond Side lines:** Minimum 2 mt, Surface Area up to 1 mt should be of same specifications as field of play and beyond that it may be of any specification like asphalt, Plain Cement Concrete(PCC), old synthetic turf (without shock pad) over asphalt base/PCC
- **Run off beyond Back lines:** Minimum 3 mt, Surface Area up to 2 mt should be of same specifications as field of play and beyond that it may be of any specification like asphalt, Plain Cement Concrete(PCC), old synthetic turf (without shock pad) over asphalt base/PCC etc

Note: With the above recommendation total area of Field of Play will be reduced by approx 950 sqmt which will amount to a saving of approx Rs 60 – 70 lakhs

Proposed layout of a Field of Play (Hockey)

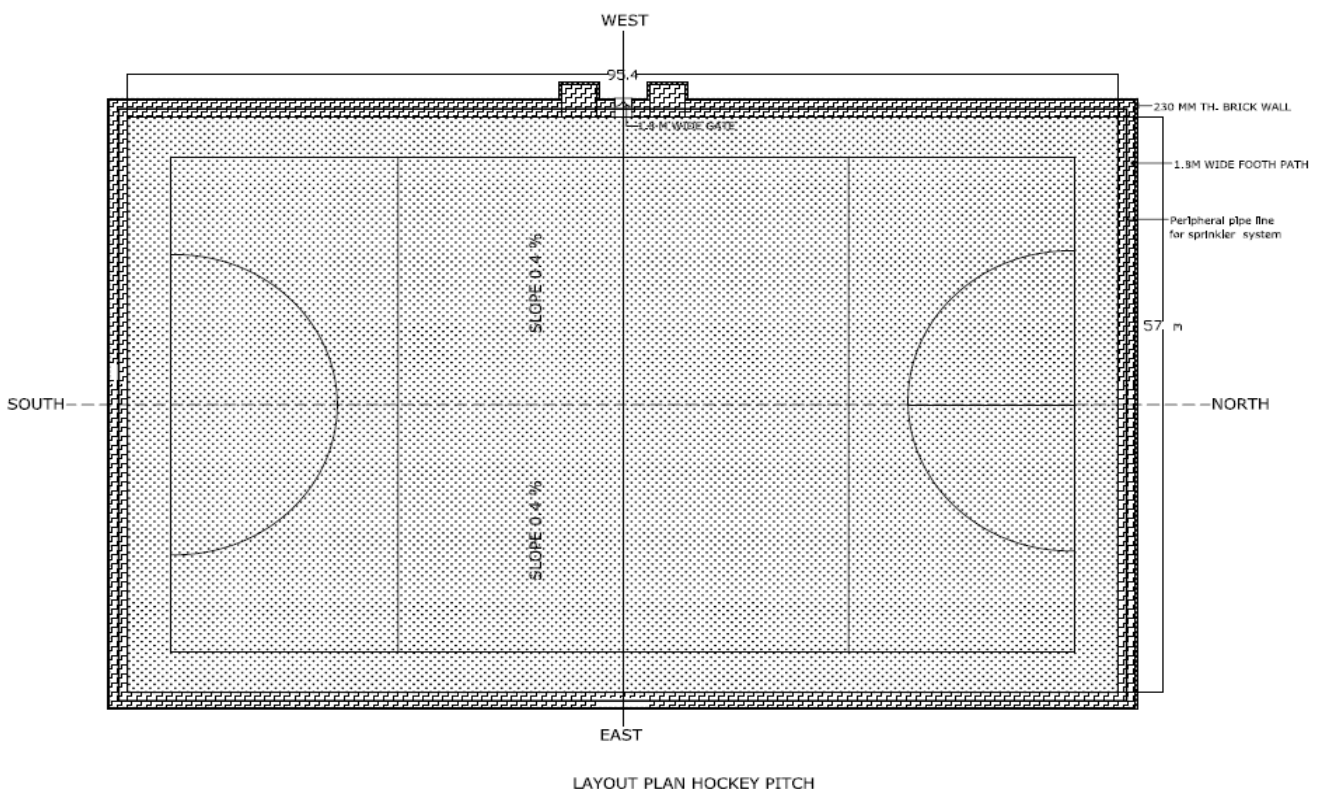

1.9 CHECKLIST FOR THE INSTALLATION OF A SYNTHETIC HOCKEY TURF

When the project is sanctioned, a Project Management Group (PMG) is constituted under the chairmanship of SAI centre-in-charge under whose area the synthetic hockey surface is being laid. Other members of the PMG shall comprise of experts in the field of hockey, hockey coach posted in the centre, officer entrusted with monitoring of infra works in the centre and a representative of PWO/Govt. construction agency entrusted with the work.

Checklist as under has been prepared as guidelines for the PMG to monitor the work::

- a) **Tender / Contract:** PMG to check and confirm from Public Works Organization/PWO, assigned the work that Tender / Contract to FIH approved registered manufacturer or their subsidiary companies only.
- b) **Product / Surface:** Product considered in the tender documents is approved by FIH. PMG to take an extract of latest certified list of manufacturers published by FIH from the PWO for record
- c) **Architectural Plan/Layout of the Surface and Field events:** **PMG** to give the proposed scope of work to the PWO for preparing the layout/Architectural plan of the Hockey surface . PWO will prepare the layout plan along with the services like drainage/ water supply/Electrical supply lines duly marked and take the approval of the PMG before execution. However it should be ensured that the sanctioned cost of the project is not exceeded.
- d) It is the responsibility of the PWO to ensure that the work is executed as per the layout plan approved by the PMG. Any changes in the layout plan during execution stage should be recorded and approved by the PMG, to avoid dispute
- e) All the technical/structural aspect related to the construction of the hockey surface is the responsibility of the PWO.
- f) Since the work is assigned to the PWO, as a deposit work, the funds are to be released in advance by the SAI centre in charge to the PWO. To ensure that there is no blockage of funds and also the progress of work is not effected due to lack of funds, a three months advance may be released by the SAI Centre in charge as per demand of the PWO.
- g) PMG to meet every fortnight at the site to ensure that the project is being executed as envisaged, resolve any pending issue hampering the work and assess the release of funds.

- h) PWO should submit the details of installation process of the synthetic turf by the manufacturer, along with the list of items and its quantities to be imported to the PMG.
- i) Funds are to be released in advance to the PWO for opening of Letter of Credit for placing order for imported items. PWO to ensure that the Govt, interest is protected and the Bank Guarantees' are taken from the manufacturer, as per the procedure being followed by CPWD in similar cases.
- j) **PMG should compare the list of items and quantities of the supply order with that required for the work as per the installation process of the manufacturer.**
- k) Custom duty exemption certificate (CDEC), to be issued by the SAI centre in charge as per the invoice. The CDEC should be issued in time else demurrage charges will have to be paid, which is construed as loss to state. **Before issue of CDEC, invoice of the items and quantity received should again be verified with the earlier list submitted by PWO (Refer, h, I, j above)**
- l) Before laying of the Shock absorbing layer and synthetic surface, the following checks should be carried out by the PMG and kept on record:
- The surface area should be flooded with water, to ensure there is no stagnation
 - The layout of the Hockey surface is as earlier approved by the PMG. However PWO shall be responsible for all the dimensions and slopes
- m) **PMG should ensure that the synthetic surface should be laid directly by the manufacture through their approved applicator only as per their installation manual.**
- n) **Testing:** FIH accredited laboratory should test the surface and FIH certification should be submitted to the PMG for record.
- o) **Sprinkler System:** Single key, fully automatic computerized sprinkler system should be installed, which should cover the entire ground in the normal windy conditions also. The specifications of sprinkler system should be similar to the one laid for hockey turf in Major Dhyanchand National Stadium New Delhi
- p) **Video clippings of installation process , line marking and FIH certification process may be made and kept on record for future references**

1.10. SYNTHETIC HOCKEY SURFACE MANUFACTURER AND THEIR INDIAN REPRESENTATIVE FOR TURFS LAID IN INDIA.

S. No.	NAME OF MANUFACTURER	INDIAN REPRESENTATIVE	NAME OF BRAND
1	CC Grass F/5, Sports Center Business Building, No 1-6 Wutaishan, Nanjing 210029 Jiangsu , CHINA Tel: +86 25 86556028-8025 Email: info@ccgrass.com	Shiv Naresh Sports Pvt. Ltd. E-23, Milan Cinema Road, Karampura, Opposite Karampura Post Office, New Delhi, Delhi 110015 011 2543 0429 shivnareshsports@shivnareshsports.com	Green HF
2	Desso Sports Systems BV (NV) Robert Ramlotstraat 89, 9200 Dendermonde BELGIUM Tel: +32 52 262 660 Email: pvreijen@desso.com	Sportina Exim Pvt. Ltd. 218 Champaklal Estate, Sion Circle, Sion, Mumbai - 400022, Near Cinemax Cinema +(91)-22-38566057	DD Sportilux SL
3	FIELDTURF TARKETT 2 rue de l'Egalite, 92748 Nanterre Cedex, France, Tel: 33 1 4120 4382 E-mail:- benjamin.chardon@tarkett.com	Great Sports Infra Flat No. 101, Plot No.52, Street Number 2, Chikoti Gardens, Begumpet, Hyderabad, Telangana 500016 Phone: 040 2776 4900 E-mail:- info@greatsportsinfra.com	HOCKEY GOLD
4	Greenfield BV Nylonstraat 7 , 8281 JX Genemuiden ,Netherlands Tel: +31 38 3372010 Email: info@greenfields.eu	Syncott International J - 219, Lane W-15, Western Avenue Sainik Farms, New Delhi, Delhi 110062 Phone: 011 2955 5390 E-mail:- seema@syncotts.com	Greenfields TX
5	Grass Manufacturers Pty Ltd. Unit 8.1, 1A Hale Street, Portair Industrial Estate, NSW 2109, Australia Tel: +61 2 9316 7244 E-mail:- brent@grassman.com.au	Maverick Turf Corporation 456/C, 2nd Floor, 14th Main, 9th Cross, 2nd Phase, J.P.Nagar, Bengaluru, Karnataka 560078 Tel : 098453 69337 info@maverickturf.com	Tru Play
6	POLYTAN/ STI Mr. Stephen Niven, CEO Suit 504, 5/F, Chinachem Leighton Plaza, 29 Leighton Road, Causeway Bay, Hong Kong Tel (852) 2882 3655 / Fax (852) 28823825 E-Mail:- sniven@polytan.com.au	Advanced Sport Technologies LLP 2277, Raja Park, Rani Bagh, New Delhi - 110034 Tel No. 011-29232939 / 41650045 E-Mail:- info@ast-sports.com	POLIGRAS
7	Suntex Sports Turf (Kunshan) Corp. No 188 Shengxi Road Economic & Technical Development Zone, Kunshan City, Jiangsu Province, CHINA Tel: +86 512 577 19988 Email: suntex@suntex88.com	Chadha Sports 109, Bhagat Singh Market, New Delhi - 110001 Ph. No. 011-23363084 chadhasportsmail@yahoo.com	STH-13
8	Tiger Turf 229 IKON, Droitwich Road, Hartlebury Worcestershire, DY10 4EU United Kingdom Tel: +44 1299 25 39 66 Email: info@tigerturf.co.uk	Altius Sports & Leisure Pvt. Ltd. B1/30, Hauz Khas, Aurobindo Marg, New Delhi, Delhi 110016 Tel:- 011- 2656 1112 nasir.ali@altiusports.com	Tiger Turf TT37

Note:- The above list is just for information. The Indian representative may change with time. There are other manufactures of Synthetic Hockey Turf for with FIH manual can be referred.

**INTERNATIONAL ASSOCIATION
OF
ATHLETICS FEDERATIONS
(IAAF)**



ATHLETIC TRACK

2. IAAF (International Association of Athletic Federation)

In order to comply with modern standards of construction, the International Association of Athletics Federations decided to publish this “Track and Field Facilities Manual” in addition to the IAAF Competition Rules. The manual contains detailed and more clearly defined specifications for the planning and construction of Track and Field facilities than those contained in the IAAF Competition Rules. The aim is to pay greater attention to technical and performance requirements of Track and Field facilities.

2.1 TYPES OF CERTIFICATES

IAAF (International Association of Athletic Federation) approves the Athletic track based on laid down performance standards. IAAF issues two types of certificates:

- **IAAF Class 1 Athletics Facility Certificate** : Required for Outdoor competitions held under Rule 1.1 (a) i.e. competitions included in the World Athletics Series and the Athletics Programme of the Olympic Games
- **IAAF Class 2 Athletics Facility Certificate** : Required for all facilities intended for use for outdoor competitions under Rule 1.1(b) to (j) like :
 - a) The Athletics of Area, Regional or Group Games not confined to participants from a single area where the IAAF does not have exclusive control.
 - b) Regional or Group Championships in Athletics not confined to participants from a single Area.
 - c) Matches between teams from different Areas representing Members or Areas or combinations thereof) International Invitation Meetings and competitions which are categorised by IAAF as part of the global structure and approved by the Council.
 - d) Area Championships and other intra-Area competitions organised by an Area Association.
 - e) The Athletics programme of Area, Regional or Group Games, and Regional or Group Championships in Athletics confined to participants from one Area.
 - f) Matches between teams representing two or more Members or combinations thereof within the same Area, with the exception of Youth and Junior category competitions.
 - g) International Invitation Meetings and competitions, other than those referred to in Rule 1.1(e), where appearance fees, prize money and/or the value of non-cash prizes exceed USD 50,000 in total, or USD 8,000 for any one event.
 - j) Area programmes similar to those referred to in Rule 1.1(e).

In simple words all the competitions up to Commonwealth Games require only class II certified surfaces.

All synthetic Athletic tracks laid or to be laid in SAI centres are proposed to comply with IAAF Class II Athletics Facility Certificate with the exception of major competitions facility like JNS, New Delhi.

It is normal for an athletics track to be used for other sports. Generally, this involves using the interior of the 400m tracks as a pitch for soccer, American football or rugby. The Athletic track is therefore designed for multipurpose facilities with playing fields inside. To accommodate the playing fields inside, 400 m Oval Track can be of various shapes/types as under:

	Type of 400m Oval Track			
	Standard Track	Double Bend Track		
R = Radius	R = 36.50	R1 = 51.543 R2 = 34.000	R1 = 48.00 R2 = 24.00	R1 = 40.022 R2 = 27.082
G = Straights	G = 84.39	G = 79.996	G = 98.52	G = 97.256
F = Figure	F = 1.2.3a	F = 1.2.3b	F = 1.2.3c	F = 1.2.3d
Rectangular Interior Width	73.00	80.000	72.00	69.740
Length	84.39	79.996	98.52	97.256
Dimension of Segment Width	73.00	80.000	72.00	69.740
Length	36.50	35.058	27.22	29.689

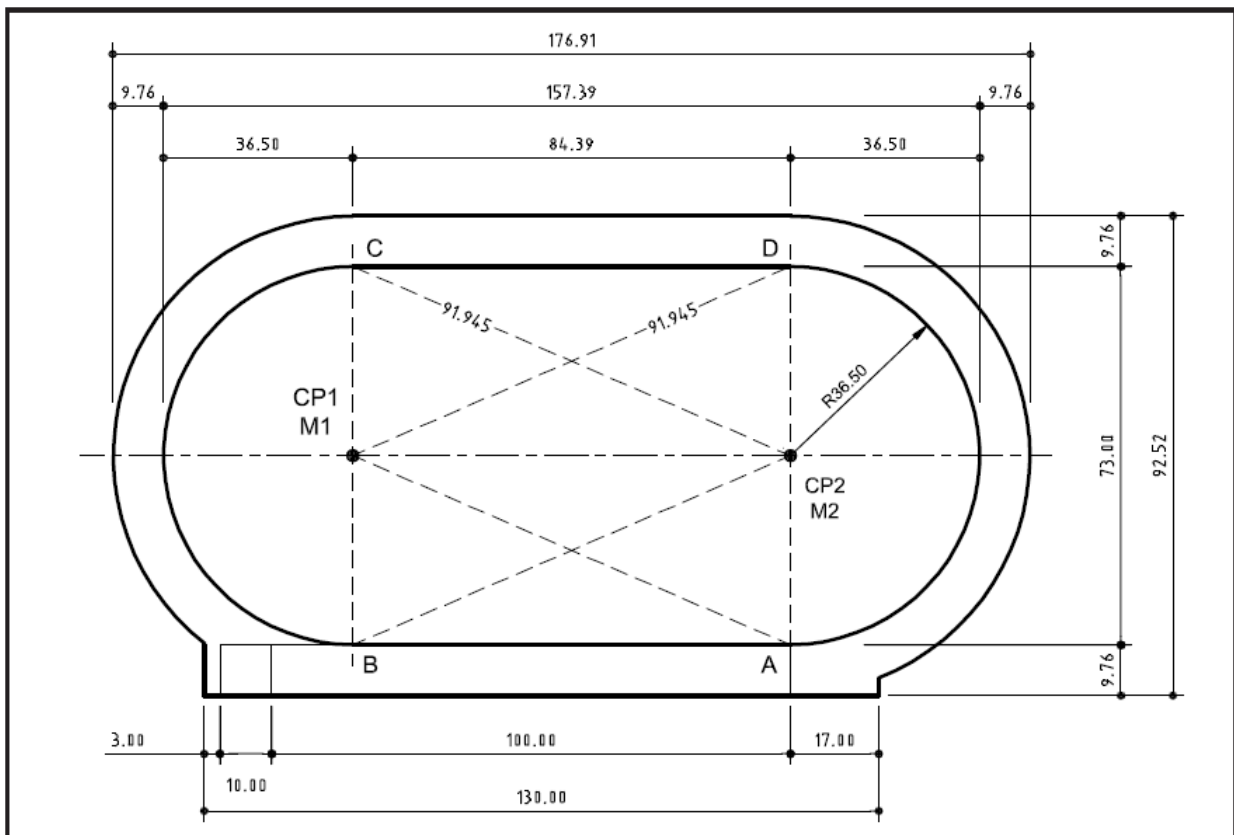

Shape and dimensions of the 400m Standard Track (Radius 36.50m)
(Dimensions in m)

Shape and dimensions of 400m Double Bend Track (Radii 51.543m and 34.00m)
 (Dimensions in m)

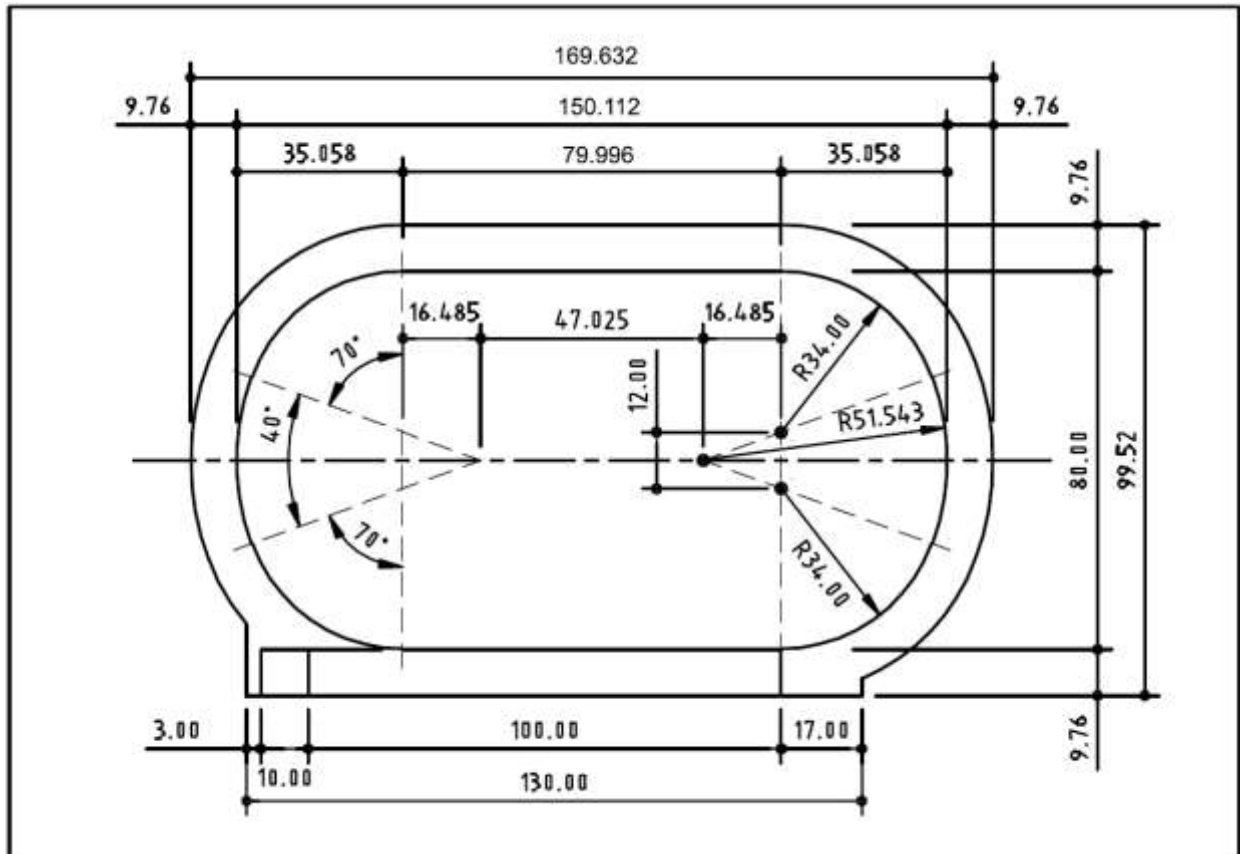

Shape and dimensions of 400m Double Bend Track (Radii 48m and 24m)
 (Dimensions in m)

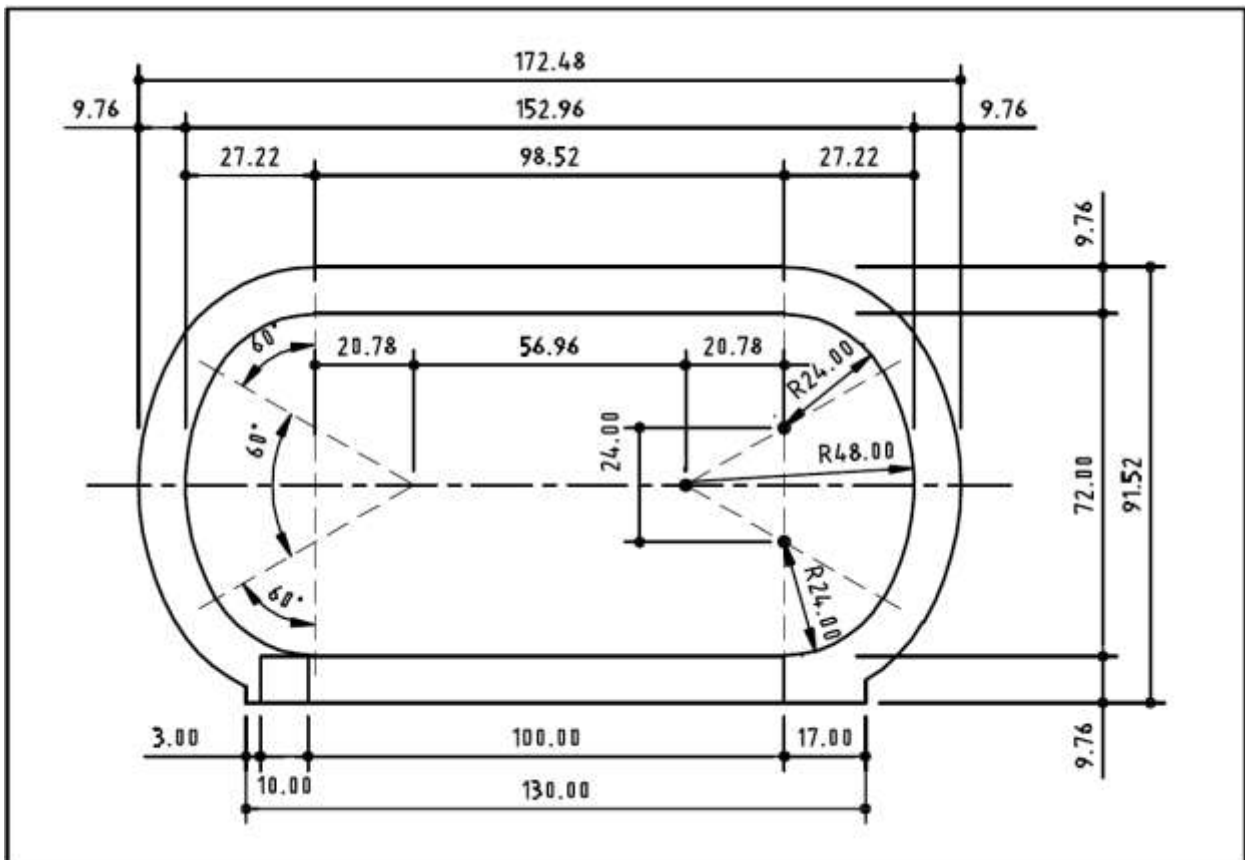

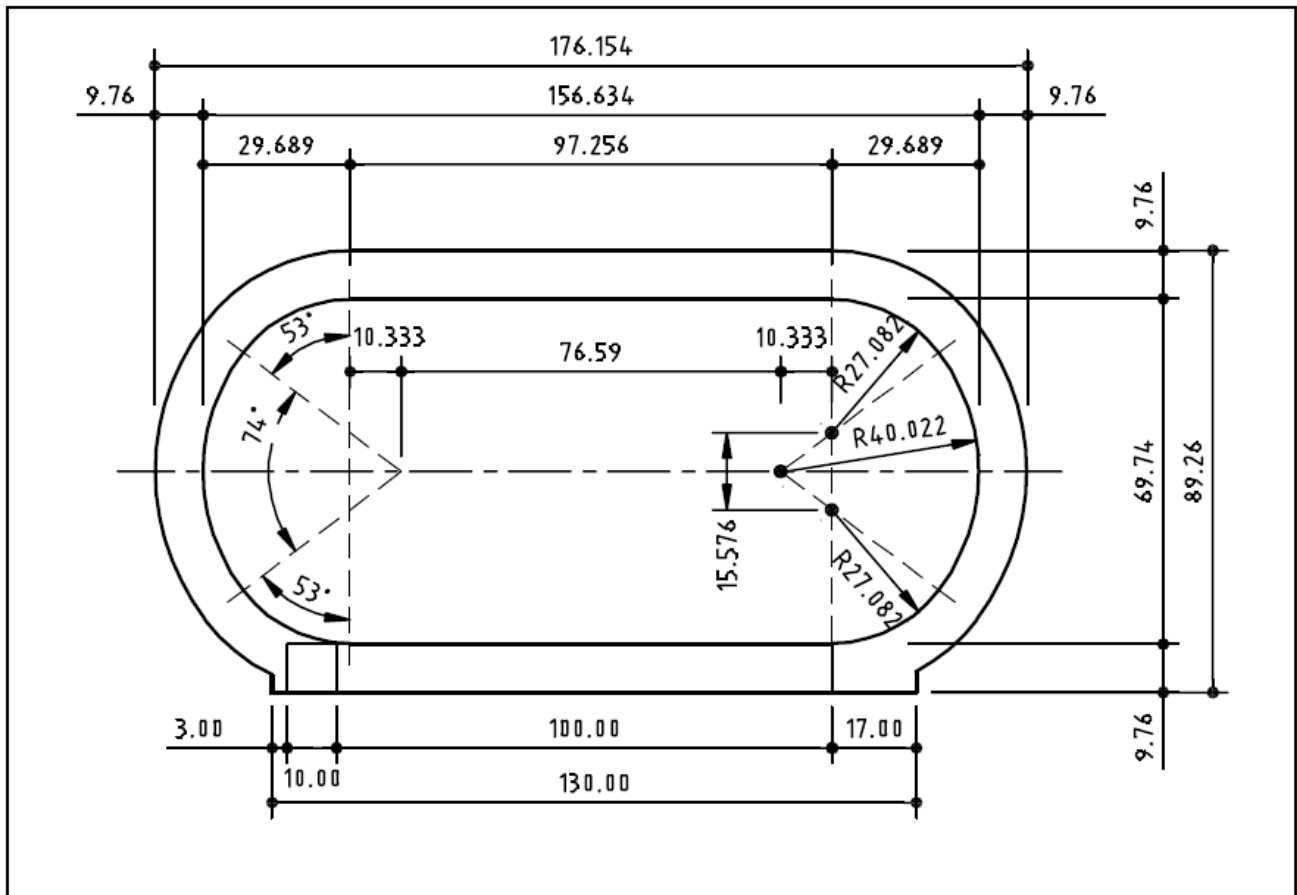

Figure 1.2.3d - Shape and dimensions of 400m Double Bend Track (Radii 40.022m and 27.082m)
(Dimensions in m)

2.2 COMPETITION AREA

General Remarks

Track and Field athletics include competition areas for running, walking, jumping and throwing events. These are normally integrated into an arena, the design of which is dictated by the 400m oval track. The dimensions given are to be adhered to. Permissible deviations are given as tolerances (+ or ± or -) after each figure. All linear measurements and levels shall be made to the nearest whole mm.

IAAF Manual stipulates dimensions and equipment for international and other high class competition by elite athletes. For club and school competitions, the dimensions of horizontal jumps landing areas, distance to take-off boards, the lengths of runways, dimensions of landing areas etc. may be reduced. The safety of athletes must be paramount in making such decisions. If you are in doubt as to what is appropriate consult your national athletics federation.

2.3 TYPES OF COMPETITION FACILITIES (Compiled from IAAF Manual)

1.14.1 Competition Area for Track Events includes:

- Oval track with at least 4 lanes (400m + 0.04m x 1.22m ± 0.01m) and safety zones measuring not less than 1.00m on the inside and preferably 1.00m on the outside
- Straight with at least 6 lanes (100m + 0.02m x 1.22m ± 0.01m for sprints and 110m + 0.02m x 1.22m ± 0.01m for hurdles)

Starting area: 3m min. (for 110m Hurdles, category V 2.5m min.).

Run-out: 17m min.

- Steeplechase track as for oval track with a permanent water jump (3.66m x 3.66m x 0.50m-0.70m) placed inside or outside the second bend

2.3.1 Competition Area for Jumping Events

The competition area for jumping events includes:

- Facility for Long Jump with runway (40m min. x 1.22m ± 0.01m), take-off board (1.22m ± 0.01m x 0.20m ± 0.002m x 0.10m max.), placed between 1m and 3m from the nearer end of the landing area, and the landing area 2.75m min. wide with the far end at least 10m min. from the take-off line).
- Facility for Triple Jump as for Long Jump except for a take-off board placed 13m min. for men or 11m min. for women from the nearer end of the landing area for international competitions. For any other competition, this distance shall be appropriate for the level of competition.
- Facility for High Jump with a semicircular runway (radius 20m min.) and landing area (6m x 4m min.).
- Facility for Pole Vault with a runway (40m min. x 1.22m ± 0.01m), a box for inserting the pole and landing area (6m x 6m min.) with an additional forward extension.

2.3.2 Competition Area for Throwing Events

The competition area for throwing events includes:

- Facility for Discus Throw with throwing circle (2.50m ± 0.005m diameter), protective cage and landing sector (80m radius, 48m chord)
- Facility for Hammer Throw with throwing circle (2.135m ± 0.005m diameter), protective cage and landing sector (90m radius, 54m chord)
- Facility for Javelin Throw with runway (30m min. x 4m), arc with a radius of 8m and landing sector (100m radius, 50.00m chord)

- Facility for Shot Put with throwing circle ($2.135\text{m} \pm 0.005\text{m}$ diameter) stop board ($1.21\text{m} \pm 0.01\text{m} \times 0.112\text{m} \times 0.10\text{m} \pm 0.02\text{m}$) and landing sector (25m radius, 15m chord)

2.3.3 Facilities for Track Events

- Track events include sprint, middle and long-distance, hurdle and steeplechase events. The direction of running is anti-clockwise.
- The 400m oval track usually forms the basis of a multi-sports arena. Its dimensions are, therefore, dependent on the requirements of other sports. When integrating the straight and the steeplechase into the oval track, deviations will arise in the longitudinal slopes in some areas.
- Although there are a number of different layouts for the 400m oval track, it is IAAF's objective to create uniform criteria, not only with a view to improving the performance parameters necessary for equal opportunities for all athletes and for the suitability for competition but also to simplify the principles of construction, surveying and certification of facilities.
- Experience has shown that the most suitable 400m oval tracks are constructed with bend radii of between 35m and 38m, with an optimum of 36.50m.
- **IAAF recommends that all future tracks are constructed to the above specification and this will be referred to as the "400m Standard Track".**

2.3.4 MISC DETAILS OF 400 M STANDARD ATHLETIC TRACKS

- Layout of the 400m Standard Athletic Track has the advantages of a simple construction, straight and curved sections of almost equal length and uniform bends which are most suitable to the running rhythm of athletes. Furthermore, the area inside the track is large enough to accommodate all throwing events and also a standard football pitch (68m x 105m).
- The 400m Standard Track comprises 2 semicircles, each with a radius of 36.50m, which are joined by two straights, each 84.39m in length (see Figure above). This diagram indicates the inside edge of the track which must have a kerb, that should be coloured white, with a height of 0.05m to 0.065m and a width of 0.05m to 0.25m. The inner edge of the track is 398.116m in length ($36.50\text{m} \times 2 \times \pi + 84.39\text{m} \times 2$). This length for the inner edge gives a length of 400.001m ($36.8\text{m} \times 2 \times \pi + 84.39\text{m} \times 2$) for the theoretical line of running (measurement line) at a distance of 0.30m from the kerb.

- The inside lane (lane 1) will, therefore, have a length of 400.001m along its theoretical line of running. The length of each of the other lanes is measured along a theoretical line of running 0.20m from the outer edge of the adjacent inside lane (Figure 2.2.1.1b)
- **.All lanes have a width of 1.22m ± 0.01m.**
- **The 400m Standard Track has 8, 6 or occasionally 4 lanes but the last is not used for international running competition.**
- 9 is the maximum number of oval lanes that should be provided at a facility as otherwise there is too much advantage gained by the athlete in the outside lane in a 200m race over the athlete in the inside lane.
- It is permissible to have any number of sprint lanes on the straights.

2.3.4 Dimensional Accuracy of the 400m Standard Track

The dimensional accuracy required for all classes of competition is as under:

- on the outside edge of the inner track border:
 - 84.390m ± 0.005m for each of the two straights (2 readings)
 - 36.500m ± 0.005m for 12 points per semicircle (including kerb) on the arc of the circle approximately 10.42m apart (24 readings)
- Alignment of the kerb in the area of the two straights: no deviations greater than 0.01m (2 readings). Ideally, the length of the kerb in the straight and the length of the outer lane measured along the outside edge of the lane should be equal.

2.3.5 Safety of the 400m Standard Track

The 400m Standard Track must have an obstacle-free zone on the inside at least 1.00m wide and should have on the outside an obstacle-free zone at least 1.00m wide. Any drainage system positioned under the kerb must be flush with the surface and level with the track.

The outer obstacle-free zone must also be flush with the surface of the track.

2.3.6 Marking of the 400m Standard Track

- All lanes shall be marked by white lines. The line on the right hand of each lane, in the direction of running, is included in the measurement of the width of each lane.
- All start lines (except for curved start lines) and the finish line shall be marked at right angles to the lane lines.
- Immediately before the finish line, the lanes may be marked with numbers with a minimum height of 0.50m.
- All markings are 0.05m wide.

- All distances are measured in a clockwise direction from the edge of the finish line nearer to the start to the edge of the start line farther from the finish.
- The essential requirement for all start lines, straight, staggered or curved, is that the distance for every athlete, when taking the shortest permitted route, shall be the same, and not less than the stipulated distance, i.e. no negative tolerance.
- For races of 800m or less, each athlete shall have a separate lane at the start.
- Races of up to, and including 400m shall be run entirely in lanes.
- Races of 800m shall start and continue in lanes until the end of the first bend.

2.3.7 Facilities for Jumping Events

The Jumping events are Long Jump, Triple Jump, High Jump and Pole Vault. These facilities preferably should not be on the inside field because of the potential safety and event scheduling problems.

2.3.8 FACILITY FOR LONG JUMP

The Long Jump facility includes a runway, a take-off board and a landing area. Usually, it is placed outside the track along one of the straights with two adjacent runways with a landing area at each end, thus allowing competition in either direction by two groups of athletes simultaneously.

2.3.9 Runway for the Long Jump

The length provided for the runway shall be 40m min. and is measured from the beginning of the runway to the take-off line. The runway shall be $1.22\text{m} \pm 0.01\text{m}$ wide. It shall be marked by white lines 0.05m wide or broken lines 0.05m wide, 0.10m long and 0.50m apart. The runway is usually covered with the same surface as the track.

2.3.10 Take-off Board for the Long Jump

The take-off board shall be rectangular and shall measure $1.22\text{m} \pm 0.01\text{m}$ long, $0.20\text{m} \pm 0.002\text{m}$ wide and not more than 0.10m deep. It shall be coloured white. The surface of the take-off board must be flush with the surface of the runway. In the case of a runway with a permanent surface, this requires a built-in installation tray made of corrosion-protected metal in which the take-off board can be correctly positioned. During sport-free periods, the take-off board can be removed. If it has a track surface on its reverse side, it can be turned over and used as part of the runway. This makes it possible to combine Long and Triple Jump with two or three take-off boards (which can be used on both sides) on a Triple Jump runway.

2.3.11 Landing Area for the Long Jump

The landing area must be 7m to 9m long depending on the distance between its nearer end and the take-off line and shall be 2.75m min. wide. Generally, a landing area length of 8m placed 2m from the take-off line is recommended. The landing area shall, if possible, be so placed that the middle of the runway coincides with the middle of the landing area. If two landing areas are situated parallel side by side, the distance between them must be at least 0.30m. If two landing areas are staggered, the separation between the two areas must also be at least 0.30m. The landing area should have a border not less than 0.05m wide and 0.30m high, rounded off towards the inside (e.g. wooden plank or concrete border with soft covering) and level with the ground. The landing area must have a water permeable substructure or a suitable drainage system (draining well or canal connection) and be filled with sand to a depth of not less than 0.30m at the edges and slightly deeper at the centre.

2.3.12 Layout of the Facility for the Triple Jump

Except for the placement of the take-off board, the same facilities are used for Triple Jump as for Long Jump. For international competition, it is recommended that the take-off board shall be not less than 13m for men and 11m for women from the nearer end of the landing area. For other competitions, this distance shall be appropriate for the level of competition.

2.3.13 Layout of the "Standard Competition Area"

The Field Events are evenly distributed over the arena to avoid congestion and to satisfy the needs of the spectators. This layout avoids undue disruption of events by ceremonies and counterbalances the concentration of interest in the finish area. The layout is, of course, flexible. Local climatic conditions particularly wind conditions and the effects of the rays of the sun on jumpers / valuator must be considered.

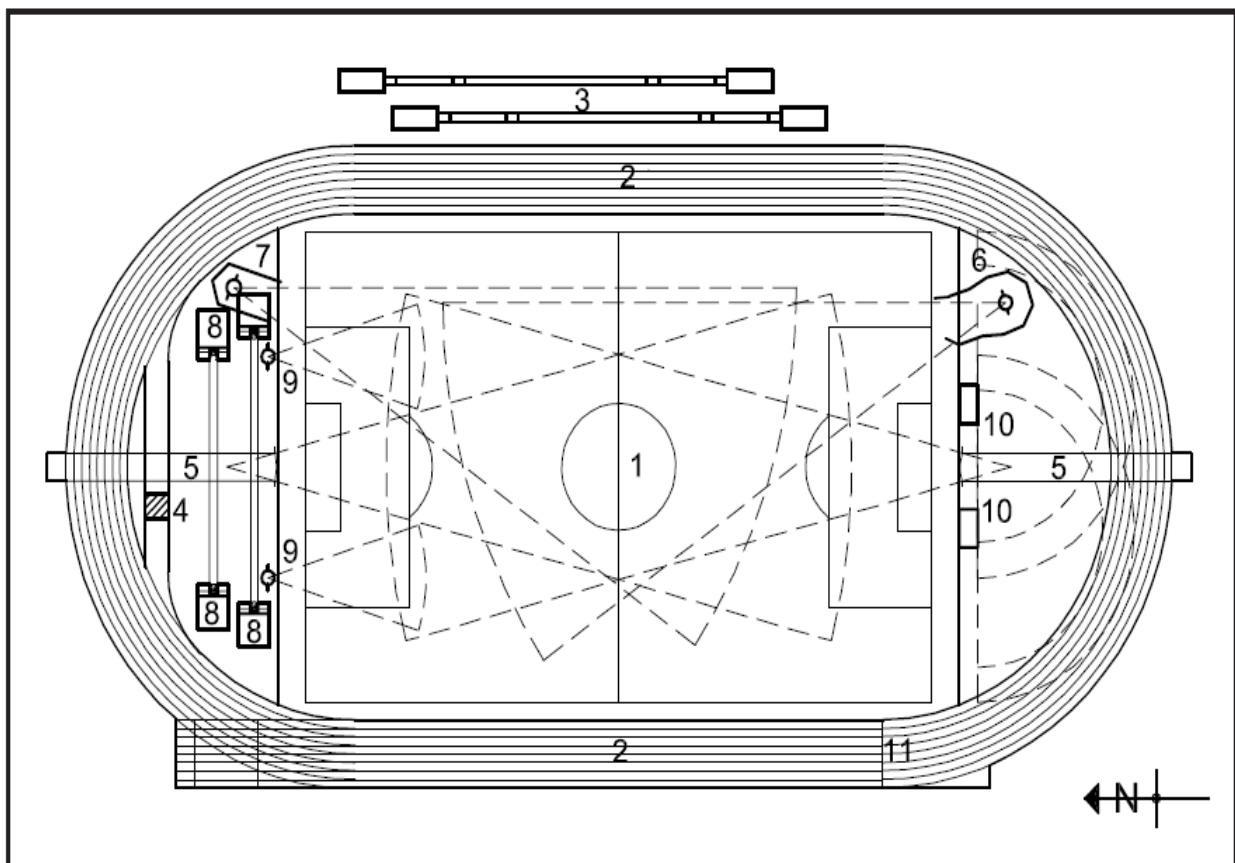

Figure 2.5a - Standard layout of competition facility

- | | |
|------------------------------------|-------------------------|
| 1 Football pitch | 7 Discus Throw facility |
| 2 Standard Track | 8 Pole Vault facility |
| 3 Long and Triple Jump facility | 9 Shot Put facility |
| 4 Water jump | 10 High Jump facility |
| 5 Javelin Throw facility | 11 Finish line |
| 6 Discus and Hammer Throw facility | |

2.3.14 Alternatives for Training Facilities

During the planning and construction stages for training facilities, a variety of alternatives are permissible. Long jump facilities, for example, may have several runways next to each other. High Jump training facilities may be arranged to allow for run-ups from both sides of the landing mats. Shortened runways may also be considered - especially for school sports. The size of landing mats must be commensurate with the height being jumped by the athletes. However, a prerequisite for all facilities is the observance of safety aspects.

Generally, training facilities cater for several events of Track and Field and, where the facilities for Track and Field are combined with small pitches, for ball games. Of course, this type of design will normally preclude a simultaneous use of the facilities for the individual sports available there. Organisational measures can be implemented to overcome this disadvantage (e.g. scheduling of training times). On the other hand, this

type of design will result in considerable savings in terms of space and building costs.
Alternative layouts for training facilities as under are compiled from IAAF Handbook

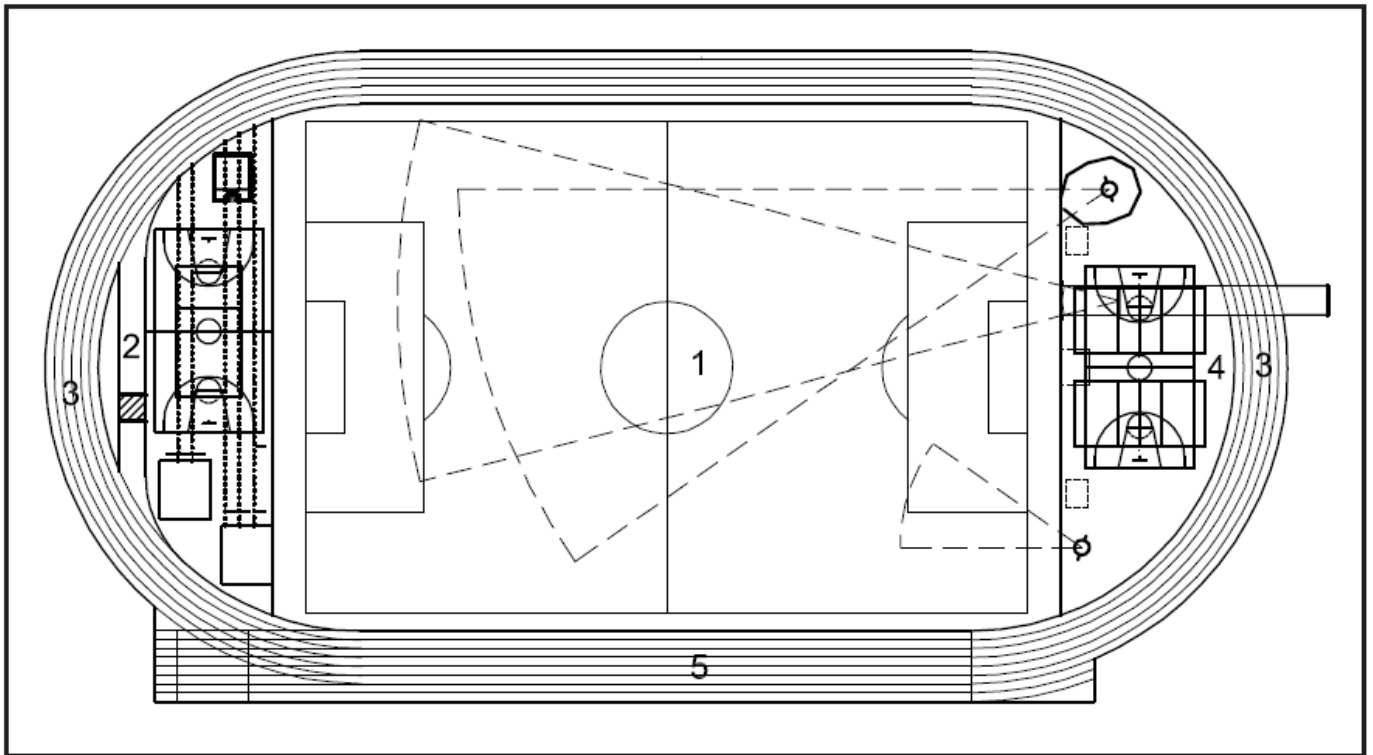

400m Standard Track as a warm-up and training area

(Dimensions in m)

- 1 Track interior (playing field and landing area for throwing events)
- 2 Segment with water jump, Pole Vault, Long and Triple Jump, and ball games area for basketball and volleyball
- 3 Six-lane oval track
- 4 Segment with Discus / Hammer circle, Shot Put circle, High Jump, Javelin Throw, ball games area for volleyball (2 courts) and basketball
- 5 Eight-lane straight

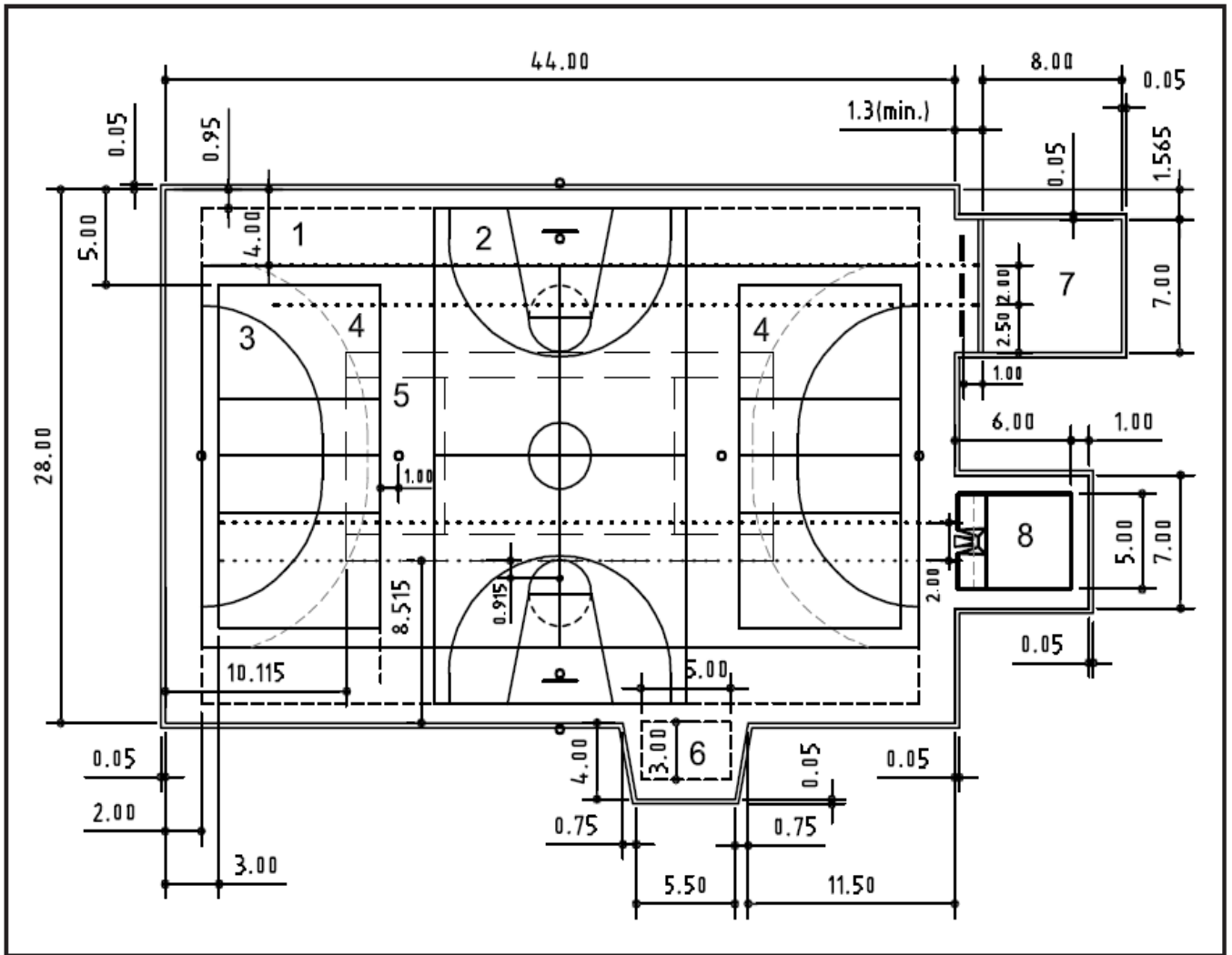

Multi-purpose facility for ball games and athletics

(Dimensions in m)

- 1 Rectangular field, 26.10m x 40m
- 2 Basketball court, 14m x 26m
- 3 Handball court, 20m x 40m
- 4 Volleyball court, 9m x 18m
- 5 Tennis court, 10.97m x 23.77m
- 6 High Jump
- 7 Long Jump
- 8 Pole Vault

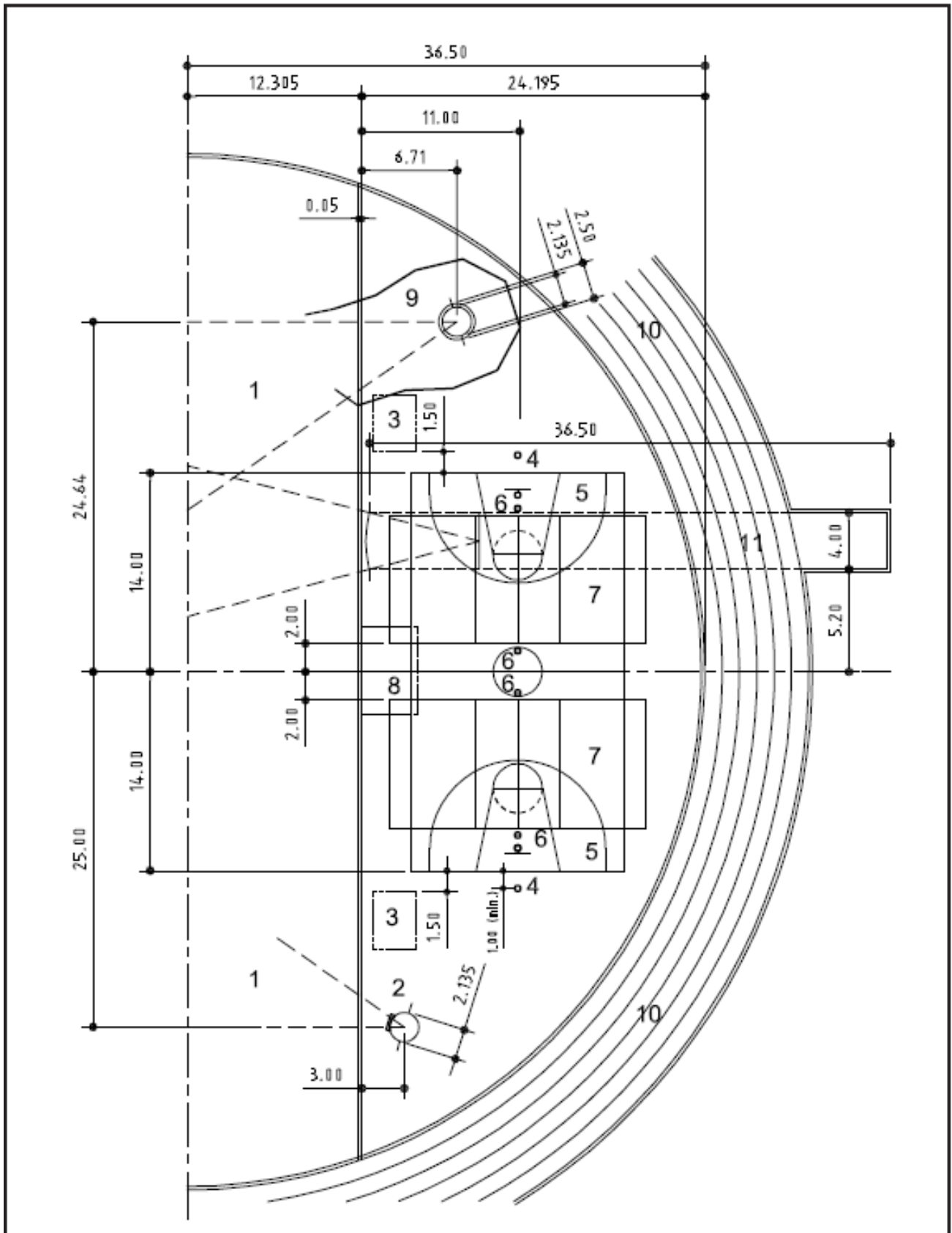
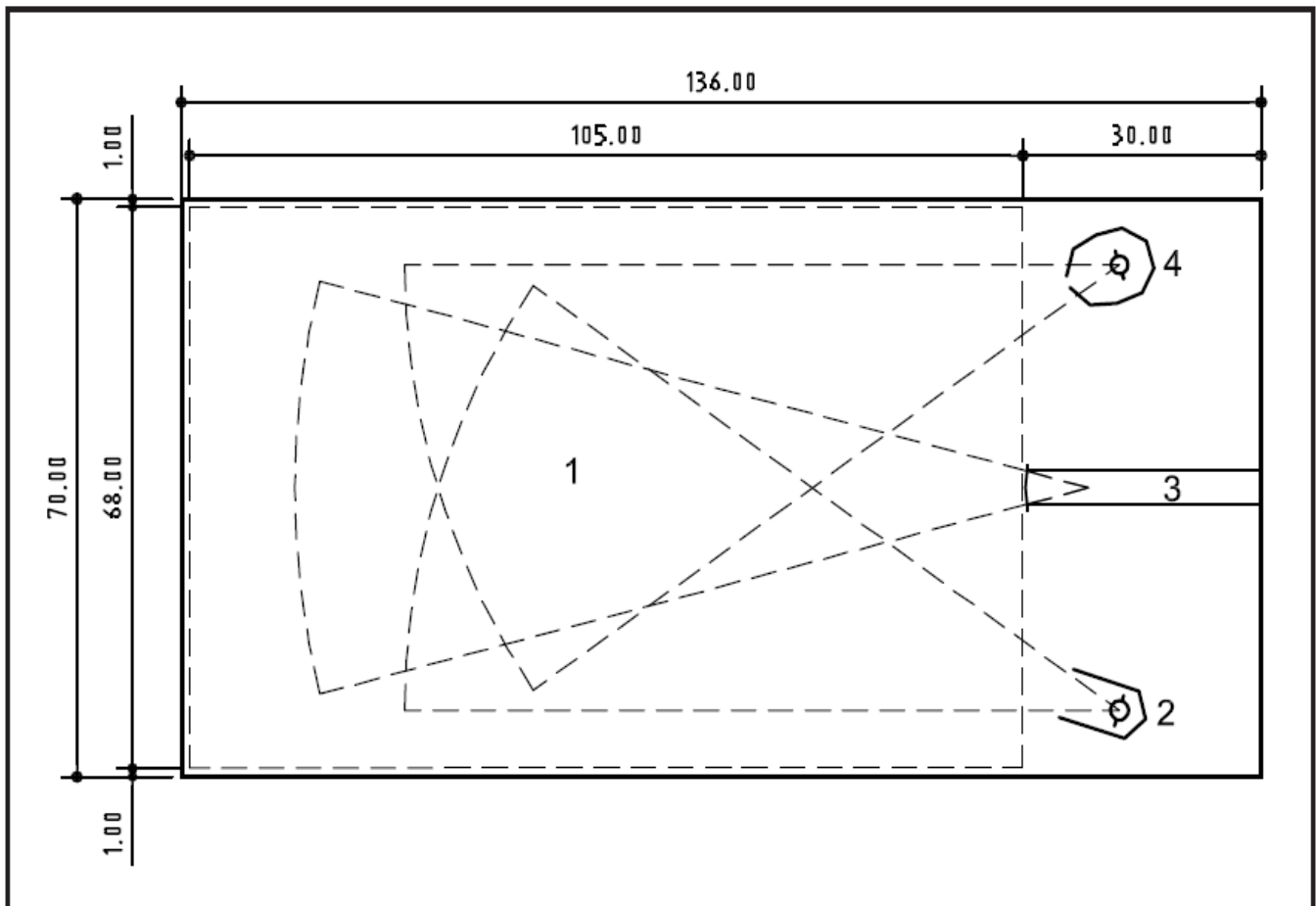

Figure 2.6.3 - Detail of the southern segment of the plan shown in figure 2.6.2a
(Dimensions in m)

- | | |
|--|--|
| 1 Grass playing field | 7 Volleyball court, 9m x 18m |
| 2 Shot Put | 8 Competition High Jump with 6m x 4m landing mat |
| 3 High Jump training area with 4m x 3m landing mat | 9 Discus / Hammer Throw |
| 4 Ground anchor for basketball backboard support | 10 Six-lane oval track |
| 5 Basketball court, 15m x 28m | 11 Javelin runway |
| 6 Socket for volleyball net post | |

Warm-up and training area for throwing events (Dimensions in m)



- 1 Playing field and landing area
- 2 Discus circle with safety cage
- 3 Javelin runway
- 4 Hammer circle with safety cage

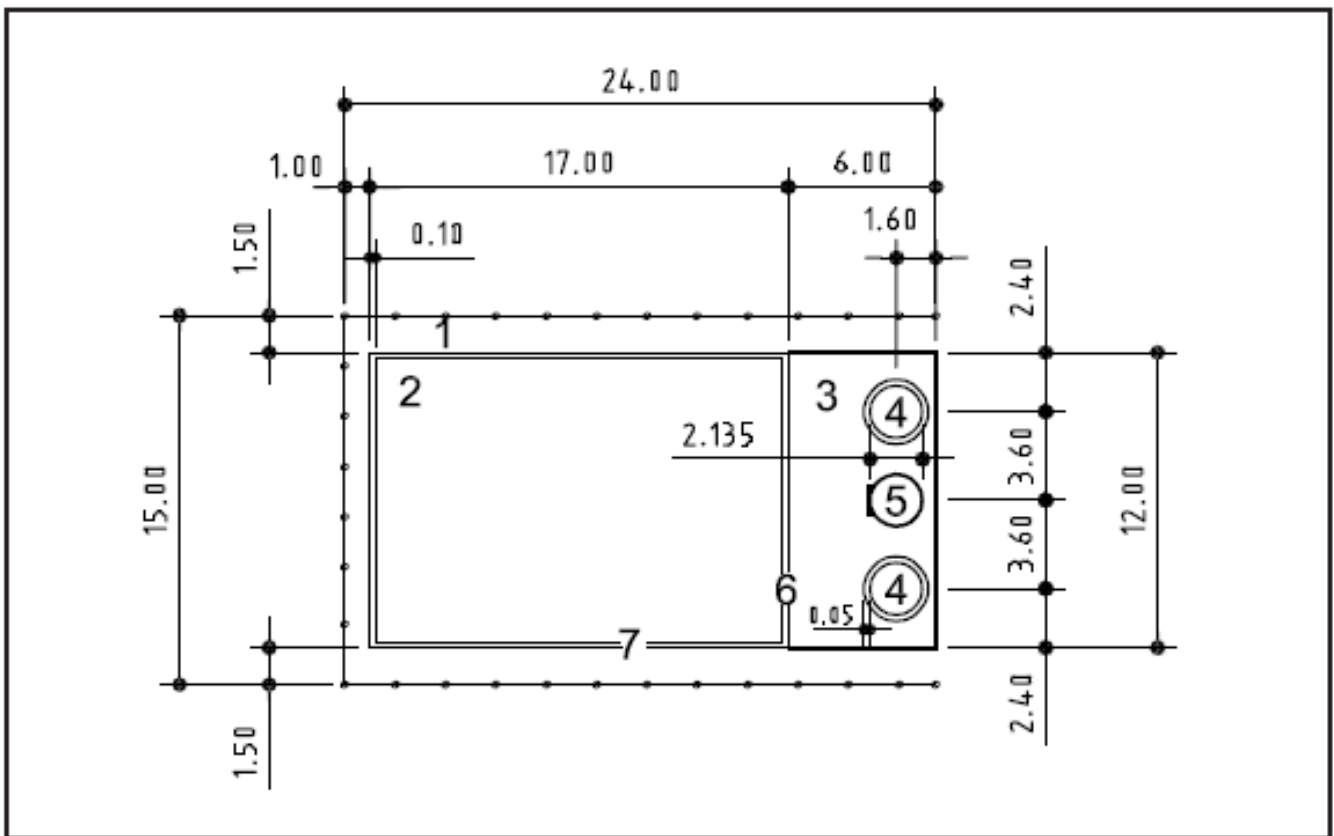

Figure 2.6.5b - Shot Put training area (Dimensions in m)

- 1 Periphery with safety barrier and shot-resistant surface
- 2 Landing area (unbound mineral surface)
- 3 Concrete area with three Shot Put circles
- 4 Marked circle
- 5 Recessed competition circle with stopboard
- 6 Separation between concrete slab and landing areas
- 7 Landing area surround with soft covering for safety

If international standard athletes are to use the Shot Put facility particularly if they use a two-handed over the shoulder training technique then the length of the Shot Put training area shown in Figure 2.6.5b needs to be increased.

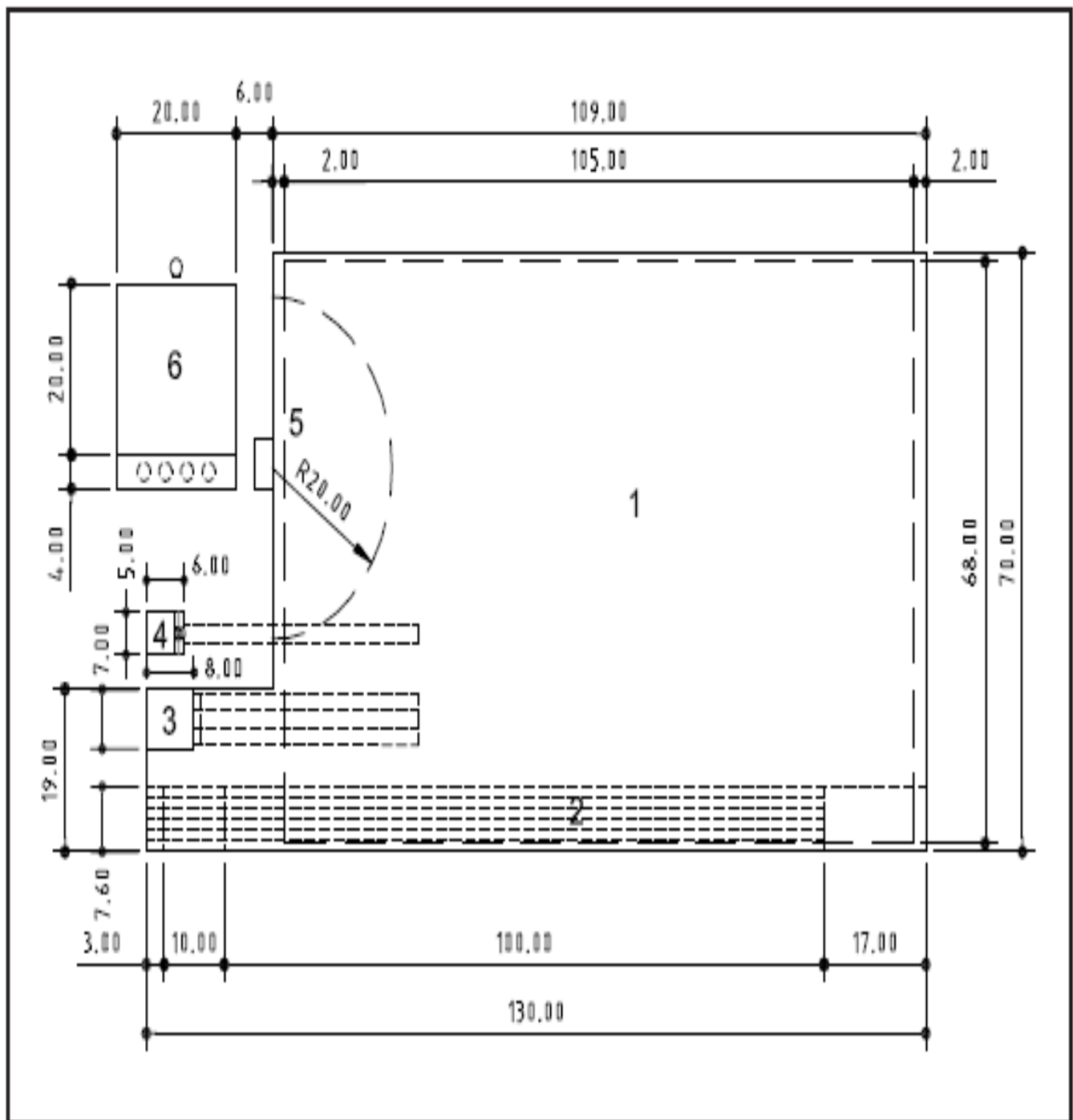

Figure 2.6.6a - Multi-purpose facility for ball games and athletics (Dimensions in m)

- 1 Playing field, 68m x 105m (unbound mineral surface)
- 2 Six-lane straight marked on the playing field
- 3 Three-lane long jump
- 4 Pole Vault
- 5 High Jump
- 6 Shot Put area with four painted circles on a concrete slab and one competition circle

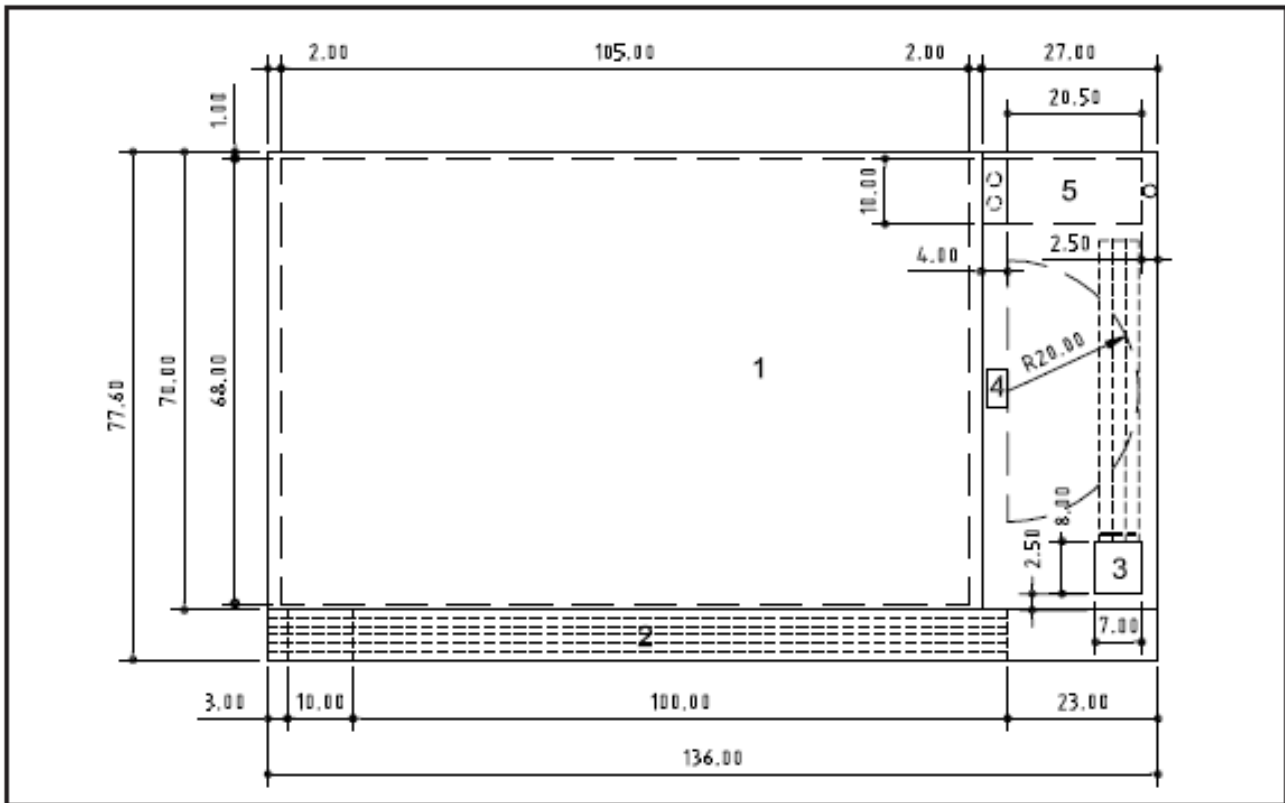
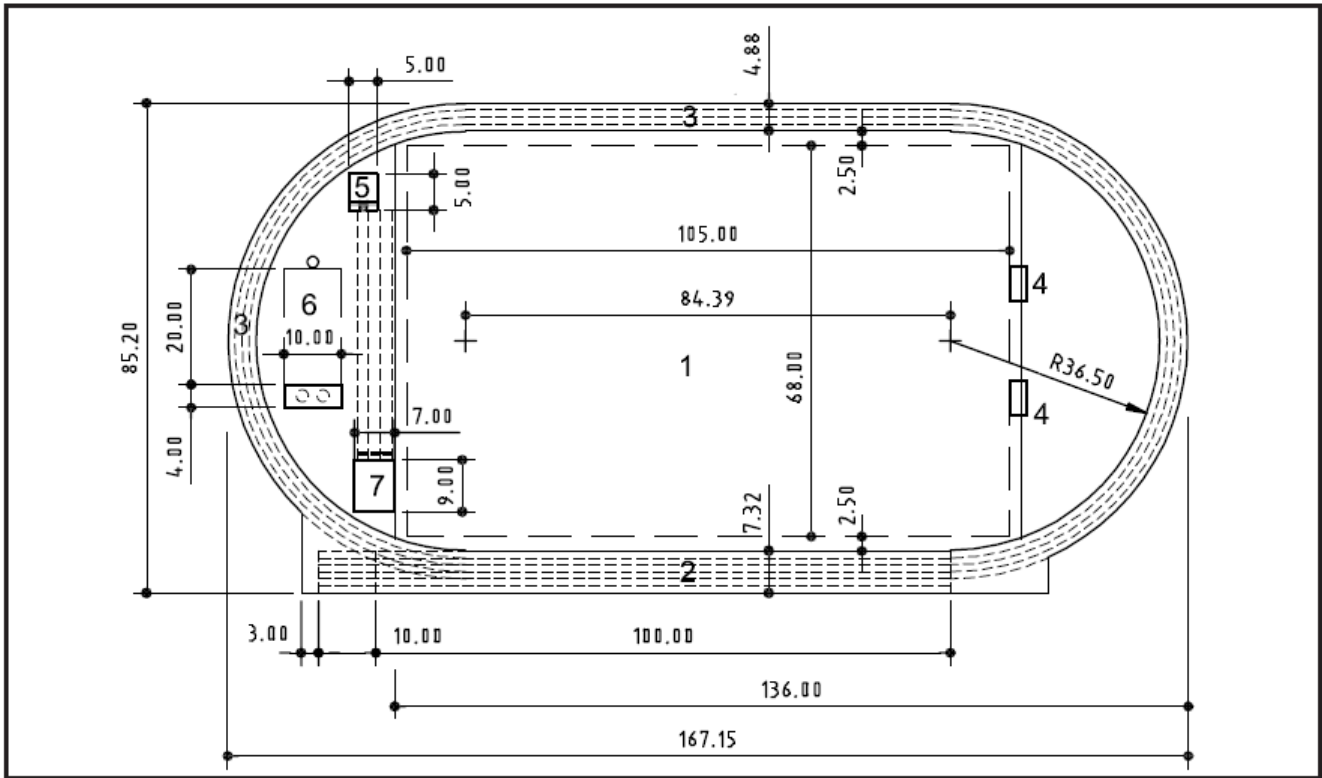

Figure 2.6.6b - Multi-purpose facility for ball games and athletics (Dimensions in m)

- | | |
|---|--|
| 1 Playing field, 68m x 105m (grass surface) | 4 High Jump |
| 2 Six-lane straight | 5 Shot Put area with two painted circles on a concrete slab and one competition circle |
| 3 Three-lane long jump | |



Warm-up area with 400m Standard Track and large playing field (Dimensions in m)

- | | |
|-----------------------------|--|
| 1 Playing field, 68m x 105m | 5 Pole Vault |
| 2 Six-lane straight | 6 Shot Put area with two painted circles on a concrete slab and one competition circle |
| 3 Four-lane oval track | 7 Long and Triple Jump |
| 4 High Jump | |

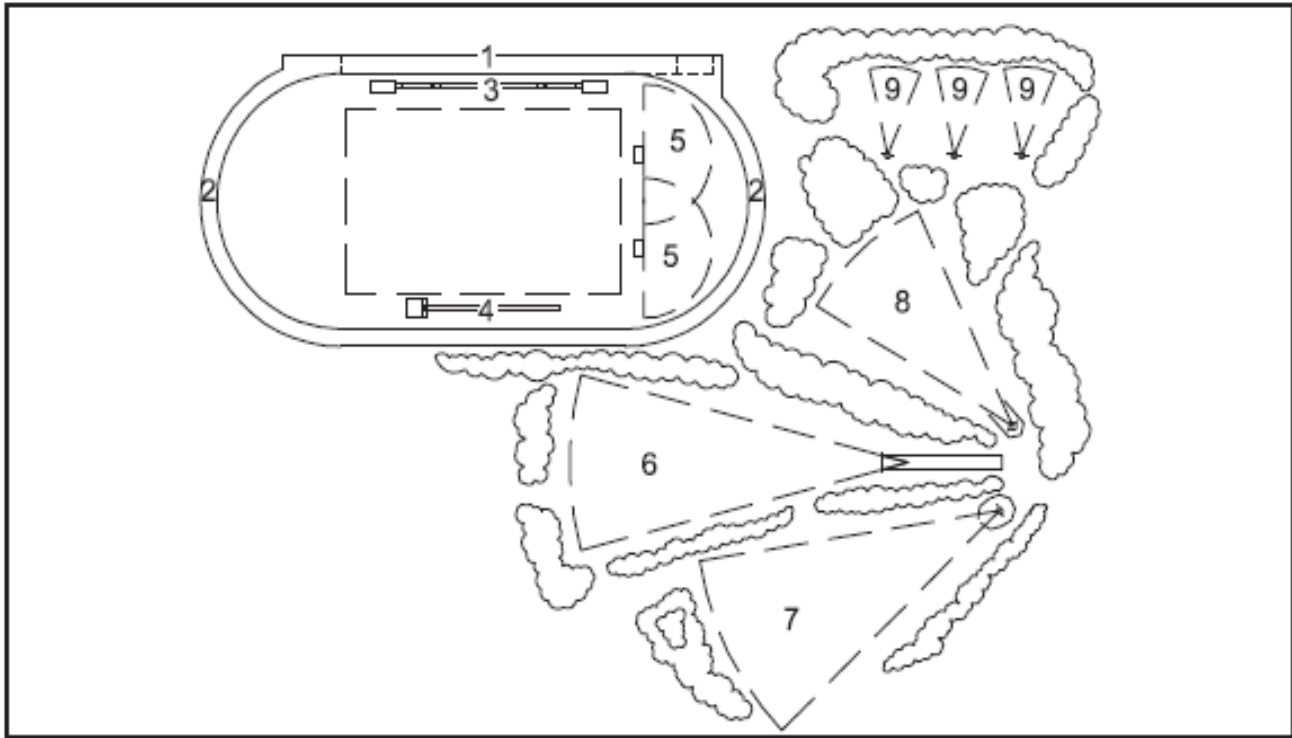

Figure 2.6.6d - Warm-up area with separate areas for throwing events

- | | |
|------------------------|-----------------|
| 1 Four-lane straight | 6 Javelin Throw |
| 2 Four-lane oval track | 7 Hammer Throw |
| 3 Long and Triple Jump | 8 Discus Throw |
| 4 Pole Vault | 9 Shot Put |
| 5 High Jump | |

2.4 PERFORMANCE REQUIREMENTS

The requirements of a synthetic surface for an athletics track are two-fold:

- Is it effective as an athletics surface?
- Is it durable - that is will it retaining its effectiveness over a reasonable period of time?

An athletic facility should meet these requirements at the time of a competition. However, it is obvious that surfaces must retain their characteristics in the long-term, both because of the need to ensure a wide network of good quality facilities around the world, and as a matter of commercial prudence on the part of the owners of the facilities.

Synthetic surfaced athletics tracks represent a considerable financial investment and it is only natural that they should be put to the best possible use. This means that their use for training purposes should be actively encouraged. To achieve a reasonable return on their investment, owners should expect the synthetic surface to last at least eight to ten years before requiring major repairs. Obviously the life of a surface is dependent on the level of usage.

2.4.1 Durability

The durability of synthetic surfaces relates to how well they withstand mechanical wear as well as their resistance to environmental factors. Outdoor athletics probably represents the most severe all-round test for synthetic surfaces. The surface must withstand the combined effects of compaction, abrasion, spike-damage, UV light, water, and variations in temperature. Indoor surfaces have somewhat less to contend with in that generally there would be no effects due to water and UV. It is hardly surprising that in the long-term, synthetic surfaces do sustain mechanical damage and in addition they may discolour and they may change in resilience.

Mechanical damage would mainly take the form of loss of texture from the surface layer, together with cutting from the athletes' spiked footwear. Obviously these effects would be most apparent in the heavily used areas such as the inside two lanes of the track, the end of the Javelin runways, the High Jump and the Pole Vault take off points.

Loss of adhesion to the base or edge kerbings might occur, as might loss of adhesion between individual layers of multi-layer systems. This adhesion loss would result in delimitation of the surface from the base or from itself.

All mechanical breakdown of the surface will be exacerbated by the influence of the environment to which the surface is exposed.

Examples of this "accentuation" of wear are:

- In colder climates, freeze/thaw cycling of entrapped water can have an adverse effect on the physical integrity of spike-damaged areas, can further weaken areas of surface delimitation, and can have a generally debilitating effect on areas of a porous surface where through-drainage is not as good as it should be.
- In hotter climates, spike damage creates larger surface areas over which UV attack can occur. This can be further exacerbated in the case of composite surfaces such as sandwich systems and textures paint coated resin-bound rubber crumb systems, by the fact that mechanical damage can often expose the lower layer of the surface. These lower layers may not necessarily have been formulated for prolonged exposure to weathering.
- Hot and high humidity environments can progressively weaken the bond between the synthetic surface and the base or edge kerbings. Discolouration and changes in resilience, if they occurred at all, would tend to occur over the entire surface area of the facility.

These were fairly common problems in the early life of the synthetic surfaces industry, in the late 1960's. However, modern formulations and the attention now paid by reputable manufacturers and installers of the raw materials to quality control, compatibility and consistency of the products, has meant that the synthetic surface is likely to retain its performance properties within reasonable limits, for its full anticipated service life. Bubbling of the synthetic is often evidence of water penetrating under the synthetic surface. The point(s) of water penetration should be determined immediately, eliminated and the damaged surface repaired to prevent further damage and also for athlete safety.

2.4.2 Effectiveness

The effectiveness of the surface is a matter of prime concern to all users of a facility. Certain performance requirements must be met if athletics is to take place on the surface with comfort and safety for the athletes. These fundamental requirements have been laid down by the IAAF, and are as follows:

2.4.3 Imperfections

It is obvious that serious surface imperfections such as bubbles, fissures, delimitation etc are unacceptable on grounds of safety and because of the effect they may have on durability and on dynamic performance of the surface. Wherever they occur, they must be rectified as a matter of priority.

2.4.4 Evenness

The very tight tolerances for overall gradients permitted by the IAAF are well known, because of the need to ensure that the slope of the surface gives no assistance to athletes. On a localised level, there shall be no bumps or depressions beneath a 4m straightedge exceeding 6mm, or beneath a 1m straightedge exceeding 3mm, at any position and in any direction. There shall be no step-like irregularities greater than 1mm in height, for instance at bay joints in in-situ surfaces or at seams in prefabricated sheet.

These limits are laid down not only to ensure safety for the athletes, but also to minimise standing water after rainfall, on non-porous surfaces. The presence of large areas of standing water, or of water pounding to any significant depth in key areas of the facility such as the High Jump take off point, can lead to serious delays in the scheduling of events. The possible effect of such delays on major international events which are being televised world-wide can easily be imagined. Even for smaller national competitions, such delays can create severe difficulties for athletes, officials and spectators.

2.4.5 Thickness

The thickness of a synthetic surface is of fundamental importance to the characteristics exhibited by the surface. To a certain extent, the durability of the surface is dependent on its thickness, particularly with respect to mechanical wear.

It is also quite apparent that if the IAAF Rules permit athletes to use footwear with spikes of a certain length, the surface must be of a thickness which will be adequate to take that length of spike, plus an excess of thickness to allow for wear and weathering. It is obviously for this reason that certain areas on a facility, such as at the throwing end of the Javelin runway, and at the ends of other runways where an athlete plants his foot with considerable force and there is a greater impact on the athlete's legs, shall be of greater thickness than most areas of the synthetic surface. Not only do the longer spikes permitted for the High Jump and Javelin Throw, penetrate deeper into the surface, but the degree of damage which they inflict on the surface is that much greater.

By far the most important reason why a minimum thickness must be stipulated is that the dynamic characteristics of the synthetic surface are critically dependent on its thickness. If the surface is too thin, its force reduction and deformation properties will be adversely affected, for example it will feel hard and unyielding to athletes.

However, if it is over thick, the converse does not usually apply, that is it will not necessarily feel too soft and compliant. It is for this reason that it is not necessary to stipulate a maximum thickness of synthetic surface. The thickness of the surface shall be determined to meet force reduction and vertical deformation requirements hereunder. The IAAF Product Certificate for a

synthetic surface material indicates the absolute thickness at which a sample of the material, tested in a laboratory at laboratory temperature, complied with the specifications in the IAAF Track Facilities Testing Protocols.

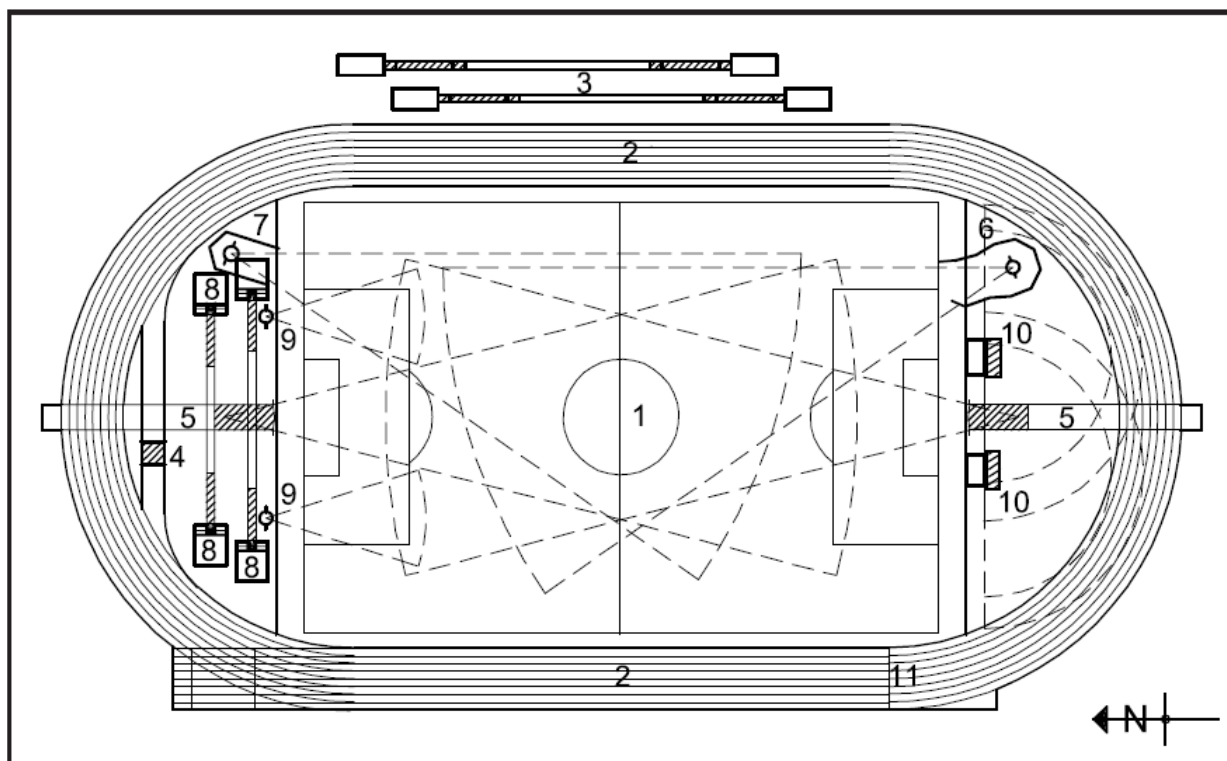

Areas with thicker layers of synthetic surface (shaded)

- 1 Football pitch
- 2 Standard Track
- 3 Long jump and Triple Jump facility
- 4 Water jump
- 5 Javelin Throw facility
- 6 Discus and Hammer Throw facility
- 7 Discus Throw facility
- 8 Pole Vault facility
- 9 Shot Put facility
- 10 High Jump facility
- 11 Finish line

Runway	Thickness mm	Length
High Jump	20	Last 3m
Triple Jump	20	Last 13m
Pole Vault	20	Last 8m
Javelin Throw	20	Last 8m plus overrun
Steeplechase Water Jump	25	Water jump landing

2.4.6 Drainage

The very slight gradients, which are permitted for athletics facilities, make the shedding of water from non-porous surfaces difficult, although not impossible. The presence of large areas of standing water, or of small areas in key locations such as the High Jump take-off point, can seriously delay the schedule of a major competition. It is for this reason that the IAAF stipulates that when completely covered with water and allowed to drain for 20 minutes,

there shall be no area of synthetic surface where the depth of residual water exceeds the texture depth of the surface. Porous surfaces should rarely give problems of this nature. If such problems do occur, they are invariably the result of either the excessive application of the textures paint coating, or of inadequate porosity in the sub base foundations for the facility or in the drainage system taking water away from the base construction.

2.5 Hydraulic Dimensioning of the Ground Drainage System

If only seepage water from the top surface or ground and stratum water has to be carried away, hydraulic calculations are not needed due to the comparatively small area of gathering ground of sports facilities. The following pipe diameters have proved adequate:

- Drainage channels within the sports areas (suction) - **65mm**
- Collection lines, ring mains for carrying off volumes of water from Playing field drainage channels for a sports area of up to 3500m² - **100mm**
- Collection lines, ring mains for carrying off volumes of water from playing Field drainage channels for a sports area of between 3501m² and 5000m² - **125mm**
- Collection lines, ring mains for carrying off volumes of water from playing Field drainage channels for a sports area of between 5001m² to 7500m² - **150mm**
- Collection lines, ring mains for carrying off water from playing field drainage channels for sports area of between 7501m² and 15,000m² - **200mm**

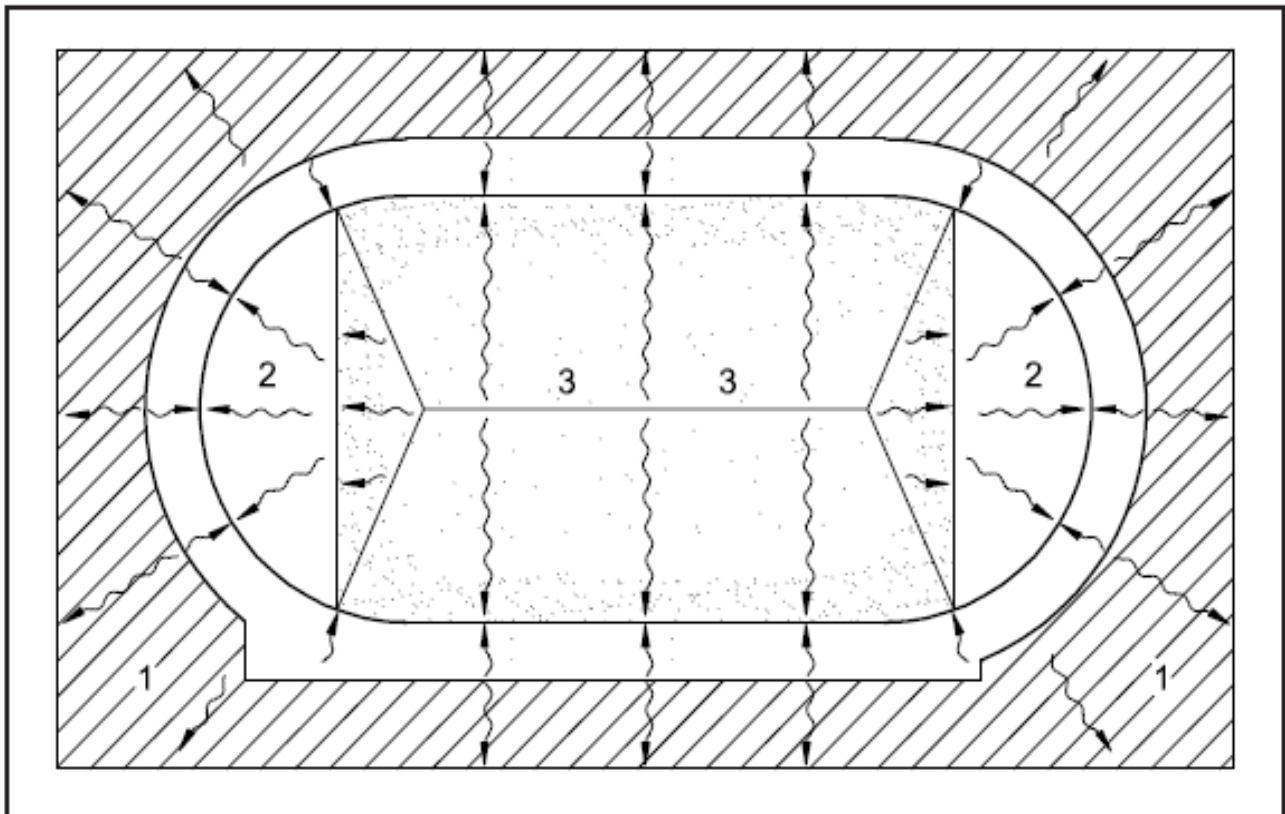

Figure 3.3.1 - Direction of flow of the surface water and discharge coefficients of the respective surfaces (in brackets)

- 1 Groundwater, vegetation areas (0.25), paved paths (0.60), asphalted paths (0.80), waterbound paths (0.30)
- 2 Unbound mineral surface (0.50), non-permeable synthetic surface (0.90), permeable synthetic surface (0.50), turf (0.25)
- 3 Turf (0.25), synthetic turf (0.60)

Note: for more details IAAF Track and Field Facilities Manual may be referred

2.6. TESTING OF SYNTHETIC TRACK SURFACE

The performance of the surface for athletics is obviously of paramount concern to the IAAF, The testing and investigation of these facilities is a much specialised activity, requiring complicated test apparatus and considerable experience in its use and the interpretation of the results generated. It is for this reason that the IAAF has enlisted the assistance of a network of test laboratories around the world, all suitably equipped and experienced in athletics track testing. The list of current IAAF accredited laboratories for testing synthetic track surfaces can be found on the IAAF website.

The best check of the quality of the finished track facility is to have an in-situ performance test undertaken by an IAAF accredited laboratory. Such a test is mandatory for a facility seeking an IAAF Class 1 certificate. Where an in-situ test is not being undertaken, it is recommended that for quality assurance purposes the surfacing installer is instructed to

prepare control samples at the rate of one sample per 600m² of installed surface. The samples should be cast beside the track using the same materials and techniques. The absolute thickness of the samples should be the same thickness as listed on the IAAF Product Certificate for the synthetic material. The size of the samples should not be less than 600mm x 600mm.

Synthetic Athletic tracks are laid by manufacturers approved and certified by IAAF. There are three types of Synthetic Athletic surface popularly used and approved by IAAF

- Full PUR Type
- Sandwich Type
- Spray Type

The thickness of Synthetic track shall be as approved by IAAF for a particular manufacturer

2.6.1 Full PUR type Synthetic Athletic Turf:

It is a three layer system

Base Layer : Polyurethane embedded with SBR granules

Central Layer : Micro foam layer that increases force reduction

Top Layer: Polyurethane embedded with UV resistant EPDM rubber granules.

- This track is expensive compared to other types
- **Recommended to be laid in SAI Regional Centres/Academic Institution/Stadium where National Camps are likely to be held.**



2.6.2 Sandwich Type Synthetic Athletic Turf:

It is a three layer system

Base layer: Polyurethane binder and SBR granules laid with the specialised paver

Central layer: Seal coat using polyurethane and EPDM powdered rubber

Top layer : Premium polyurethane embedded with EPDM rubber granules

- This turf is cheaper by 15% to 20% than the cost of full PUR system)
- Refurbishment of the surface is cheaper.

Recommended to be laid in SAI Regional Centres & major STCs/SAG Centres where National camps are not held.



2.6.3 SPRAY COATTYPE SYNTHETIC ATHLETIC TURF:

It is a two layer system

Base layer: Polyurethane binder and SBR granules

Top layer : Spray coat of polyurethane mixed with EPDM granules

- This turf is cheaper by 20% to 25% of the cost of Sandwich system and about 40% to 50% cheaper than cost of full PUR system)
- **Recommended to be laid in all remotely located STC/SAG centres with the approval of DG SAI.**
- Refurbishment is cost effective



Special Note

- The installation of any polymeric synthetic athletics track surface should be done during the spring/summer/dry months
- The minimum absolute thickness of the synthetic athletic track shall be as approved by IAAF for the particular product of the licensed manufacturer

International Association of Athletics Federations
CERTIFICATION SYSTEM

List of Certified Track Surfacing Products - as at 6 January 2015

THE IAAF IS PLEASED TO CONFIRM HERewith THAT THE FOLLOWING PRODUCTS HAVE BEEN TESTED AND MEET THE TECHNICAL REQUIREMENTS FOR USE IN ALL INTERNATIONAL ATHLETICS COMPETITIONS IF INSTALLED TO AT LEAST THE ABSOLUTE THICKNESS NOMINATED FOR THE PRODUCT.

	COMPANY	COUNTRY	PRODUCT	ABSOLUTE THICKNESS	DESCRIPTION
1	APT	USA	Rekortan M 99	15.0mm	Full PUR
2	APT	USA	Spurtan BV	14.1mm	Sandwich
3	APT	USA	Spurtan BS	13 mm	Spray coat
4	APT	USA	Spurtan BSS	13.5mm	Spray coat
5	APT	USA	Rekortan G	14.5mm	Full PUR
6	Ares Sports Surfaces	USA	Apollo	13.0mm	Prefabricated
7	Baoding Chaoda Sports Facilities	CHN	CD-II-2	14.0mm	Full PUR
8	Baoding Great Wall	CHN	Great Wall	15.1mm	Full PUR
9	CONICA AG	SUI	Conipur MX+	15.1mm	Full PUR
10	CONICA AG	SUI	Conipur M	14mm	Full PUR
11	CONICA AG	SUI	Conipur SW	13mm	Sandwich
12	CONICA AG	SUI	Conipur SP	13mm	Spray coat
13	Belling Dancingsports Facilities	CHN	Dancing track	13.0mm	Prefabricated
14	Beijing Green World Sports	CHN	Zephyr Extrac	13.5mm	Prefabricated
15	Belling Lv Tong Plastic Products	CHN	Lvtong Precast Type Rubber Runway	13.2mm	Prefabricated
16	Berleburger (BSW)	GER	Regupol Compact	14.0mm	Full PUR
17	Berleburger (BSW)	GER	Regupol AG	13.4mm	Sandwich
18	Berleburger (BSW)	GER	Regupol PD-U	13mm	Spray coat
19	Beynon Sports Surfaces	USA	BSS-1000	13mm	Full PUR
20	Beynon Sports Surfaces	USA	BSS-2000	13mm	Full PUR
21	Beynon Sports Surfaces	USA	BSS-3000	13.7mm	Full PUR
22	Beynon Sports Surfaces	USA	BSS-300, Embedded	14mm	Sandwich
23	Beynon Sports Surfaces	USA	BSS-300, Encapsulated	13.0mm	Sandwich
24	Beynon Sports Surfaces	USA	BSS-100	13mm	Spray coat
25	Beynon Sports Surfaces	USA	BSS-200	13mm	Spray coat
26	Beynon Sports Surfaces	USA	BSS-1000ML	14.1mm	Full PUR
27	BSG	POL	TETRAPUR ENZ Apart II	13mm	Spray coat
28	BSG	POL	TETRAPUR ENZ Apart III/S	13mm	Sandwich
29	BSG	POL	TETRAPUR ENZ Apart III/M	14mm	Full PUR
30	Champward Chemical	TPE	CW-362, Full Pour System	15.2mm	Full PUR
31	Champward Chemical	TPE	CW-363, Sandwich System	15.1mm	Sandwich
32	Champward Chemical	TPE	CW-364, Structural Spray	13.5mm	Spray coat
33	Champward Chemical	TPE	CW-363C, Sandwich System	13.6mm	Sandwich
34	Champward Chemical	TPE	CW-361, Full Pour System	14.1mm	Full PUR
35	Chingtal Resins Chemical	TPE	Hilex-P	14.0mm	Full PUR
36	Chingtal Resins Chemical	TPE	Hilex-E	12.0mm	Sandwich
37	Duayen Yapı Ve İzolasyon Matz	TUR	Duayen Sandwich Sytem	16.4mm	Sandwich
38	Elastomer	RUS	Elastur	16mm	Full PUR
39	EPI Synthetic Surface Materials	NED	EPI Track SW	13.1mm	Sandwich
40	EPUFLOOR GmbH	GER	EPUFLOOR BSC	13mm	Spray coat
41	EPUFLOOR GmbH	GER	EPUFLOOR BM1	14mm	Full PUR
42	FDK	JPN	Type A-1	15mm	Sandwich

	COMPANY	COUNTRY	PRODUCT	ABSOLUTE THICKNESS	DESCRIPTION
43	Foshan Nanhai Fly-Step Rubber	CHN	Fly-step	13mm	Prefabricated
44	Full Ju Enterprise	TPE	Mel Nai Mat	14mm	Sandwich
45	Guangdong Batsman	CHN	Batsman Rubber Track	13.2mm	Spray coat
46	Guangzhou Disen Sports Equipment Co., Ltd.	CHN	Disen-02 Sandwich system	14.4mm	Sandwich
47	Guangzhou JRace Athletic Facilities Co., Ltd.	CHN	JRace Race Track (JR-001)	13.2mm	Spray Coat
48	Guangzhou Minglin Novel Material Technology	CHN	Minglin Rubber Track	13mm	Prefabricated
49	Guangzhou Tongxin Sports Eqp.	CHN	Tongxin (Topthink)	13mm	Prefabricated
50	Guangzhou Tongxin Sports Eqp.	CHN	Tongxin Topthink Polyurethane Track	14mm	Full PUR
51	Hasegawa	JPN	Resin Ace ST-I	16.5mm	Full PUR
52	Hasegawa	JPN	Resin Ace ST-II	13.0mm	Full PUR
53	Hasegawa	JPN	Resin Ace SST-II	14.1mm	Full PUR
54	Hasegawa	JPN	Resin Ace STUW	13.0mm	Sandwich
55	Hasegawa	JPN	Resin Ace MDS	13.0mm	Full PUR
56	Hasegawa	JPN	Resin Ace MR	13.0mm	Full PUR
57	Hasegawa	JPN	Resin Ace FT	13.5mm	Full PUR
58	Hatko Dokuma Tekstil Insaat Taahhut Ve Ticaret. Ltd. Sti	TUR	Hatko Athlon FP	15.0mm	Full PUR
59	Hatko Dokuma Tekstil Insaat Taahhut Ve Ticaret. Ltd. Sti	TUR	Hatko Athlon SW	14.1mm	Sandwich
60	Herculan	NED	Herculan SR Olympic	15.0mm	Full PUR
61	Herculan	NED	Herculan SR Sprint	14.2mm	Sandwich
62	Herculan	NED	Herculan SR Sprint S	13.5mm	Sandwich
63	Herculan	NED	Herculan SR National	12.5mm	Spray coat
64	Huadong Holding Group Wenzhou	CHN	Huadongtrack	14.0mm	Prefabricated
65	Interchemol	POL	Eltan N	13mm	Spray coat
66	Interchemol	POL	Eltan S/E	13.1mm	Sandwich
67	Interchemol	POL	Eltan S/EPDM	14.4mm	Full PUR
68	Jiangmen Changhe Chemical Ind. Group Co. Ltd.	CHN	Singa Track	12.4mm	Full PUR
69	Jiangyin Wenming Physical Plastic	CHN	Wenming SP	15mm	Spray coat
70	Jiangyin Wenming Physical Plastic	CHN	Wenming FP	13.5mm	Full PUR
71	Jiangyin Wenming Physical Plastic	CHN	Wenming SW	15.5mm	Sandwich
72	Kangnam Chemical	KOR	Neodex Emboss H	13.0mm	Full PUR
73	Kanstet	EST	VSS-1	13.2mm	Sandwich
74	Kataskeves Dapedon Ltd. (KDF)	GRE	Poltrack Spraycoat	15mm	Spray coat
75	Kataskeves Dapedon Ltd. (KDF)	GRE	Poltrack Sandwich	15.5mm	Sandwich
76	KCC Corporation	KOR	Sporthane, Embo0492 Chip	13.3mm	Full PUR
77	KCC Corporation	KOR	High Performance Sporthane	15.4mm	Full PUR
78	King Arthur	TPE	King Arthur 4-13/Protrax	13mm	Prefabricated
79	Kolon Industries	KOR	Kolon Embo Track 13	13.0mm	Full PUR
80	Kolon Industries	KOR	Kolon Embo Track 16	16mm	Full PUR
81	Lisonda Engenharia e Construções Ltda.	BRA	Lisotan S	13mm	Spray coat
82	Marchem Polyurethane Systems	USA	Tru-Motion SS	13mm	Spray coat

83	Mizuno	JPN	Mizuno Grand Track R	15.6mm	Full PUR
84	Mizuno	JPN	Mizuno Grand Track RU-1	14mm	Spray coat
85	Mondo	ITA	Sportflex Super X	13mm	Prefabricated
86	Mondo	ITA	Mondotrack	13mm	Prefabricated
87	MRI Polytech	GBR	Polytrak, Full Pour	14.6mm	Full PUR
88	MRI Polytech	GBR	Polytrak, Sandwich System	13.8mm	Sandwich
89	MRI Polytech	GBR	Polytrak Spray Coat System SC2	13.8mm	Spray coat
90	MRI Polytech	GBR	Polytrak Prefabricated System	12.6mm	Prefabricated
91	Newsage Limited, US	USA	Johnson-Fine All Weather Artificial Track-A	14.6mm	PUR with EPDM
92	Nihon Field System	JPN	All Weather S Emboss	16.5mm	Full PUR
93	Nihon Field System	JPN	All Weather Emboss S-NS	13mm	Full PUR
94	Nihon Field System	JPN	All Weather S Emboss NR	13mm	Full PUR

	COMPANY	COUNTRY	PRODUCT	ABSOLUTE THICKNESS	DESCRIPTION
95	Nippon Taliku Shisetsu	JPN	Leotan α Emboss	13mm	Full PUR
96	Nippon Taliku Shisetsu	JPN	Leotan α Emboss R type	13.1mm	Sandwich
97	Nippon Taliku Shisetsu	JPN	Leotan α Emboss Stipple	13mm	Full PUR
98	Nippon Taliku Shisetsu	JPN	Leotan α Emboss RU	15.5mm	Sandwich
99	Nissho Sports Industry Company Ltd.	JPN	Runrubber	13.4mm	Full PUR
100	Nordic Sport Eesti AS	EST	Norditan NM olympic	14.8mm	Full PUR
101	Nordic Sport Eesti AS	EST	Norditan NSW competition	14.1mm	Sandwich
102	Nordic Sport Eesti AS	EST	Norditan NSP economic	13.0mm	Spray coat
103	NOVOL	POL	Novofloor NT	13mm	Spray coat
104	NOVOL	POL	Novofloor Full PUR	13.7mm	Full PUR
105	NS Industry	KOR	NS 9 Track	13mm	Prefabricated
106	OKU En-Tout-Cas	JPN	Top Ace CL	13.0mm	Full PUR
107	OKU En-Tout-Cas	JPN	Top Ace CB	13.0mm	Sandwich
108	OKU En-Tout-Cas	JPN	Top Ace CL-A	13.0mm	Full PUR
109	OKU En-Tout-Cas	JPN	Top Ace CB-U	13.0mm	Sandwich
110	Plubber	KOR	Plubber Track, PMS13R	13.0mm	Prefabricated
111	Polimeros Especiales y Trabajos de Restauracion Arquitectonica SA de CV	MEX	Deportan S Structural Spray System	15.4mm	Spray coat
112	Polyone Co., Ltd.	KOR	Max-sprinter	14.1mm	Prefabricated
113	Polytan Sportstättenbau GmbH	GER	Polytan PUR	14.3mm	Full PUR
114	Polytan Sportstättenbau GmbH	GER	Polytan PUR Gold	14.9mm	Sandwich
115	Polytan Sportstättenbau GmbH	GER	Polytan M	14.5mm	Sandwich
116	Polytan Sportstättenbau GmbH	GER	Polytan WS	13.7mm	Spray coat
117	Porplastic	GER	Porplastic M olympic	14.8mm	Full PUR
118	Porplastic	GER	Porplastic SW	14.1mm	Sandwich
119	Porplastic	GER	Porplastic SB	13mm	Spray coat
120	Reform Spor Sstemleri	TUR	Reflim SW	13.5mm	Sandwich
121	Rephouse	MAS	Decoflex FD with Encapsulating Top Layer	16mm	Full PUR
122	Rephouse	MAS	Decoflex SW14 Athletic Flooring	14.0mm	Sandwich
123	Rephouse	MAS	Decoflex T14	14mm	Spray coat
124	Resipoly Chrysor	FRA	Reslithan PASC	16mm	Sandwich
125	Roxie Polymers	USA	epiQ TRACKS Z5000	15.0mm	Full PUR
126	Roxie Polymers	USA	epiQ TRACKS X1000	13.3mm	Sandwich
127	SamiHwa Paints	KOR	Urecoat Emboss	12.7mm	Full PUR
128	Samsung Polymer Co. Ltd.	KOR	Elastra UT-13	12.8mm	Full PUR
129	Shanghai Huiyu Fine Chemicals	CHN	Lesutan P	13.8mm	Full PUR
130	Shanghai Huiyu Fine Chemicals	CHN	Lesutan S	13mm	Sandwich
131	Shanghai Huiyu Fine Chemicals	CHN	Lesutan V	13.3mm	Spray coat
132	Sintetika-2	RUS	Syntepol-S	13.7mm	Full PUR
133	Sports Techno Wako	JPN	PERFECTACE AF-J	13mm	Spray coat
134	Sports Techno Wako	JPN	PERFECTACE UR	13.7mm	Full PUR
135	Stockmeyer Urethanes	GER	Alsatan / Stobitan	15.2mm	Full PUR
136	Stockmeyer Urethanes	GER	Alsatan / Stobitan SW	13.3mm	Sandwich
137	Stockmeyer Urethanes	GER	Alsatan / Stobitan SC	13.2mm	Spray coat
138	Stockmeyer Urethanes	GER	Alsatan XS	15mm	Full PUR
139	Stockmeyer Urethanes	GER	Stobitan SSC	13mm	Spray coat
140	Strabag AG	AUT	STRASport Meeting-Track	14.2mm	Spray coat
141	Syspor International	MAS	Sprint SW	15mm	Sandwich
142	T & F Material	TPE	Supertrack	13.5mm	Prefabricated
143	T & F Material	TPE	Super SP Track	13.4mm	Sandwich
144	T & F Material	TPE	Super SW Track	15.5mm	Sandwich
145	Taiwan Chi-Ly Chemical Industry	TPE	Taiwan Chi-Ly Full PUR system	13mm	Full PUR
146	Taiwan Chi-Ly Chemical Industry	TPE	Chily Sandwich system	14mm	Sandwich
147	Taiwan Chi-Ly Chemical Industry	TPE	Taiwan Chi-Ly Sandwich system	13.7mm	Sandwich
148	Tianjin Dingqing	CHN	Aolida Athletic Track	13.4mm	Prefabricated rubber sheet
149	Tianjin Novotrack Rubber Products	CHN	Novotrack	13mm	Prefabricated
150	TILIA S.A.	POL	EPUFLOOR SC	13.2mm	Spray coat
151	TILIA S.A.	POL	EPUFLOOR BSW	13.8mm	Sandwich
152	Unipart	IRI	Unisport PU 232	15.7mm	Full PUR
153	Yokohama Rubber Surfacing	JPN	Surfam RU-E-1	15mm	Sandwich
154	Yokohama Rubber Surfacing	JPN	Surfam UE-2	13mm	Full PUR
155	Yu Tai Paint Co. Ltd.	TPE	UT-501-15	17.3mm	Full PUR

2.7. SUMMARY OF RECOMMENDATIONS FOR LAYING OF SYNTHETIC ATHLETIC TRACK IN SAI CENTRES/ACADEMIC INSTITUTION:

- Full PUR type synthetic turf is recommended to be laid in SAI Regional Centres/Academic Institution/Stadium where National Camps are likely to be held.
- Sandwich type synthetic turf is recommended to be laid in SAI Regional Centres/Academic Institutions & major STCs/SAG Centres where National camps are not held.
- Spray Coat type synthetic turf is recommended to be laid in all remotely located STC/SAG centres with the approval of DG SAI.

Note:

- Construction of Athletic track with field event facilities costs around Rs 6 to 7 Crores.
- Each lane of track is minimum 500 sq. mt and costs about Rs 35 – 40 Lakhs and 'D' area where field events are located is about 2000 sq mt each and costs about Rs 1.2 to 1,5 Crore.

The Athletic track and field facilities should be designed for optimum utilization

- Standard 8 Lanes Synthetic track along with all facilities for field events should be laid in the Regional Centres/Academic Institutions where Track and Field competitions and National camps are likely to be held
- In all other Regional centres/Academic Institutions, 6 lane Athletic Track should be provided, that will be cost effective. For provision of field events, refer note below
- In STCs/SAG Centres, 4 lane Synthetic Athletic Track should be provided for training purpose. For provision of field events, refer note below

Provision of Field Events:

- Field event facilities may be provided as required. It is observed that Pole vault, Hammer/Discuss throw and high jump facilities are rarely used in many SAI centres. Field event facilities may be provided separately as required.

SAI Operation Division should approve the proposed field event facilities to be provided in Regional centres/Academic Institutions/STCs/SAG Centres as per the requirement. Athletic track and field may accordingly be designed for optimum use as it will result in considerable savings in terms of cost. Alternative layouts for training facilities have been compiled above from IAAF Handbook.

- Football ground and other sports like Handball, Volleyball, and Basketball may also be planned inside the Athletic track as illustrated above, as it will result in considerable savings in terms of space and cost.

2.8. CHECKLIST FOR THE INSTALLATION OF A SYNTHETIC ATHLETIC TRACK

When the project is sanctioned, a Project Management Group (PMG) is constituted under the chairmanship of SAI centre-in-charge under whose area the synthetic athletic track is being laid. Other members of the PMG shall comprise of experts in the field of athletics, athletic coach posted in the centre, officer entrusted with monitoring of infra works in the centre and a representative of PWO/Govt. construction agency entrusted with the work.

Checklist as under has been prepared as guidelines for the PMG to monitor the work::

Tender / Contract: PMG to check and confirm from Public Works Organization/PWO, assigned the work that Tender / Contract to IAAF approved registered manufacturer or their subsidiary companies only.

Product / Surface: Product considered in the tender documents is approved by IAAF. PMG to take an extract of latest certified list of manufacturers published by IAAF from the PWO for record.

Architectural Plan/Layout of the Track and Field events : PMG to give the proposed scope of work to the PWO for preparing the layout/Architectural plan of the Athletic track and field events. PWO will prepare the layout plan along with the services like drainage/ water supply/Electrical supply lines duly marked and take the approval of the PMG before execution. However it should be ensured that the sanctioned cost of the project is not exceeded.

It is the responsibility of the PWO to ensure that the work is executed as per the layout plan approved by the PMG. Any changes in the layout plan during execution stage should be recorded and approved by the PMG, to avoid dispute

All the technical/structural aspect related to the construction of the athletic track is the responsibility of the PWO.

Since the work is assigned to the PWO, as a deposit work, the funds are to be released in advance by the SAI centre in charge to the PWO. To ensure that there is no blockage of funds and also the progress of work is not effected due to lack of funds, a three months advance may be released by the SAI Centre in charge as per demand of the PWO.

PMG to meet every fortnight at the site to ensure that the project is being executed as envisaged, resolve any pending issue hampering the work and assess the release of funds.

PWO should submit the details of installation process of the synthetic turf by the manufacturer, along with the list of items and its quantities to be imported to the PMG.

Funds are to be released in advance to the PWO for opening of Letter of Credit for placing order for imported items. PWO to ensure that the Govt, interest is protected and the Bank Guarantees' are taken from the manufacturer, as per the procedure being followed by CPWD in similar cases.

PMG should compare the list of items and quantities of the supply order with that required for the work as per the installation process of the manufacturer.

Custom duty exemption certificate (CDEC), to be issued by the SAI centre in charge as per the invoice. The CDEC should be issued in time else demurrage charges will have to be paid, which is construed as loss to state. **Before issue of CDEC, invoice of the items and quantity received should again be verified with the earlier list submitted by PWO (Refer, h, i, j above)**

Before laying of the Shock absorbing layer and synthetic surface, the following checks should be carried out by the PMG and kept on record:

The surface area should be flooded with water, to ensure there is no stagnation more than the permissible limits by IAAF.

The layout of the Athletic track is as earlier approved by the PMG. However PWO shall be responsible for all the dimensions and slopes

PMG should ensure that the synthetic surface should be laid directly by the manufacture through their approved applicator only as per their installation manual.

Testing: Line making of the surface should be done by the IAAF approved line marker. PWO should get the line marker survey report of the track along with the IAAF certification and submit to the PMG for record.

Video clippings of installation process, line marking and IAAF certification process may be made and kept on record for future references

2.9. SYNTHETIC ATHLETIC TRACK MANUFACTURER AND THEIR INDIAN REPRESENTATIVE FOR TRACK LAID IN INDIA

SI No.	NAME OF MANUFACTURER	INDIAN REPRESENTATIVE	NAME OF BRAND
1	<p>Advanced Polymer Technology / Polytan Mr. Stephen Niven, CEO Suit 504, 5/F, Chinachem Leighton Plaza, 29 Leighton Road, Causeway Bay, Hong Kong Tel (852) 2882 3655 / Fax (852) 28823825 E-Mail:- sniven@polytan.com.au</p>	<p>Advanced Sport Technologies LLP 2277, Raja Park, Rani Bagh, New Delhi - 110034 Tel No. 011-29232939 / 41650045 E-Mail:- info@ast-sports.com</p>	<p>Rekortan (FULL PUR) Spurtan BV (Sandwich) Spurtan BS (Spray Coat)</p>
2	<p>BASF Construction Chemicals / Conica AG Industriestrasse 26, CH - 8207 Schaffhausen Tel +41 (0) 52 644 36 00 info@conica.com</p>	<p>Shiv Naresh Sports Pvt. Ltd. E-23, Milan Cinema Road, Karampura, Opposite Karampura Post Office, New Delhi, Delhi 110015 011 2543 0429 shivnareshsports@shivnareshsports.com</p>	<p>Conipur, Conipur SW</p>
3	<p>Jiangyin Wenming Physical Plastic Co., Ltd., No. 15, Gongqing Road, Changjing Town, Jiangyin, Wuxi, Jiangsu, China (Mainland) 86-510-86315308</p>	<p>Altius Sports & Leisure Pvt Ltd B1/30, Hauz Khas, Aurobindo Marg, New Delhi, Delhi 110016 Tel:- 011- 2656 1112 nasir.ali@altiusports.com</p>	<p>BSS</p>
4	<p>Porplastic Hohenneuffenstraße 14, 72622 Nürtingen, Germany +49 7022 244500 info@porplastic.de</p>	<p>Great Sports Infra Pvt. Ltd. Flat No. 101, Plot No.52, Street Number 2, Chikoti Gardens, Begumpet, Hyderabad, Telangana 500016 Phone: 040 2776 4900 E-mail:- info@greatsportsinfra.com</p>	<p>Porplastic M Olympic, Porplastic SW</p>
5	<p>Stockmeier Urethanes Im Hengstfeld 15, 32657, Lemgo, Germany Tel: +49 5261 / 660 68- 0 E-Mail: urethanes.ger@stockmeier.com</p>	<p>Syncott International J - 219, Lane W-15, Western Avenue Sainik Farms, New Delhi, Delhi 110062 Phone: 011 2955 5390 E-mail:- seema@syncotts.com</p>	<p>Alsatan / Stobitan SW</p>

Note:- The above list is just for information. The Indian representative may change with time. There are other manufacturers of Synthetic Athletic Track for which IAAF manual may be referred.

**FEDERATION INTERNATIONALE DE FOOTBALL
ASSOCIATION
(FIFA)**



FOOTBALL

3. FOOTBALL (FIFA: FEDERATION INTERNATIONALE DE FOOTBALL ASSOCIATION)

3.1 FIELD OF PLAY:

3.1.1 Field surface

The playing field must be absolutely smooth and level. It should be of natural grass or artificial turf and in perfect condition. With natural grass, it should have an efficient watering system for use in dry weather. In cold climates The primary characteristics of a good playing field should include proper underground and surface drainage to allow play during rain and to rid the surface of water during extremely wet conditions. This is to maintain the quality of the football match and to avoid spectator frustration which could lead to loss of revenue. The playing surface should be even and level to allow the players the confidence of movement that would not contribute in any way to injury or unexpected falls. The grass should be uniform properly rooted and demonstrate vigorous growth. There should be no patches of water logging and/or ponding.

When constructing a new playing field it is vitally important to use experts who have successful experience in laying fields in a particular locality. These specialists should be familiar with the conditions of the climate, the specifics of the chosen site, the various soil conditions and their success with the chosen grasses. The preparation of the base needs careful planning and choices of layer works that would support a well-established root zone. The correct laying or planting of the field and the right choice of grasses or seeds, together with modern irrigation and adequate drainage, will result in a successful playing surface.

Keeping the field in peak condition at all times requires a proper maintenance plan and resources that include trained personnel, mechanical equipment, fertilisers and testing equipment.

Matches may be played on natural or artificial surfaces, according to the rules of the competition.

- The colour of artificial surfaces must be green.
- Where artificial surfaces are used in either competition matches between representative teams of member associations affiliated to FIFA or international club competition matches, the surface must meet the requirements of the FIFA Quality Concept for Football Turf or the International Artificial Turf Standard, unless special dispensation is given by FIFA.

3.1.2 Field markings

- The field of play must be rectangular and marked with lines. These lines belong to the areas of which they are boundaries.
- The two longer boundary lines are called touch lines. The two shorter lines are called goal lines.
- The field of play is divided into two halves by a halfway line, which joins the midpoints of the two touch lines.
- The centre mark is indicated at the midpoint of the halfway line. A circle with a radius of 9.15 m (10 yds) is marked around it.
- Marks may be made off the field of play, 9.15 m (10 yds) from the corner arc and at right angles to the goal lines and the touch lines, to ensure that defending players retreat this distance when a corner kick is being taken.

3.1.3 Dimensions

- The length of the touch line must be greater than the length of the goal line.

Length (touch line):	minimum	90 m (100 yds)
	Maximum	120 m (130 yds)
Width (goal line):	minimum	45 m (50 yds)
	Maximum	90 m (100 yds)

All lines must be of the same width, which must be not more than 12 cm (5 ins)

3.1.4 International matches

Length:	minimum	100 m (110 yds)
	maximum	110 m (120 yds)
Width:	minimum	64 m (70 yds)
	maximum	75 m (80 yds)

3.1.5 The goal area

Two lines are drawn at right angles to the goal line, 5.5 m (6 yds) from the inside of each goalpost. These lines extend into the field of play for a distance of 5.5 m (6 yds) and are joined by a line drawn parallel with the goal line. The area bounded by these lines and the goal line is the goal

3.1.6 The penalty area

Two lines are drawn at right angles to the goal line, 16.5 m (18 yds) from the inside of each goalpost. These lines extend into the field of play for a distance of 16.5 m (18 yds) and are joined by a line drawn parallel with the goal line. The area bounded by these lines and the goal line is the penalty area.

Within each penalty area, a penalty mark is made 11 m (12 yds) from the midpoint between the goalposts and equidistant to them. An arc of a circle with a radius of 9.15 m (10 yds) from the centre of each penalty mark is drawn outside the penalty area.

3.1.7 Flag posts

A flagpost, not less than 1.5 m (5 ft) high, with a non-pointed top and a flag must be placed at each corner. Flagposts may also be placed at each end of the halfway line, not less than 1 m (1 yd) outside the touch line.

3.1.8 The corner arc

A quarter circle with a radius of 1 m (1 yd) from each corner flagpost is drawn inside the field of play.

3.1.9 Goals

- A goal must be placed on the centre of each goal line.
- A goal consists of two upright posts equidistant from the corner flagposts and joined at the top by a horizontal crossbar. The goalposts and crossbar must be made of wood, metal or other approved material. They must be square, rectangular, round or elliptical in shape and must not be dangerous to players.
- The distance between the posts is 7.32 m (8 yds) and the distance from the lower edge of the crossbar to the ground is 2.44 m (8 ft).

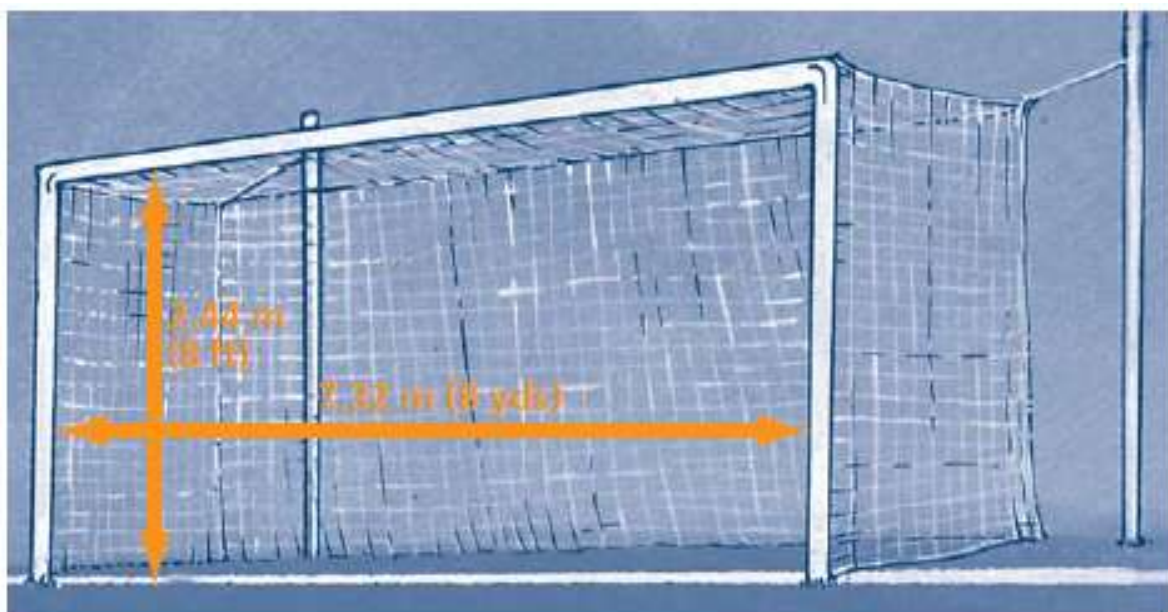

The position of the goalposts in relation to the goal line must be according to the graphics below.

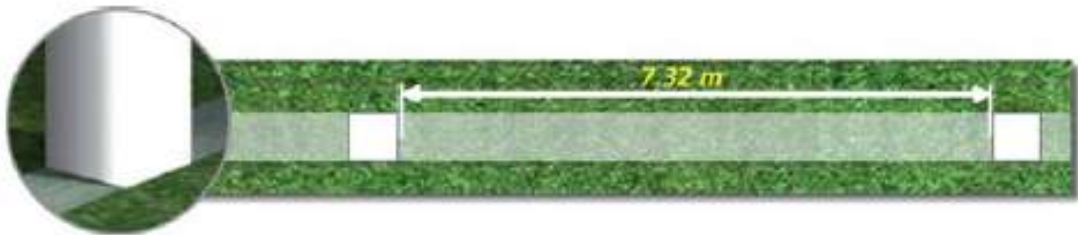

If the shape of the goalposts is square (viewed from above), the sides must be parallel or perpendicular to the goal line. The sides of the crossbar must be parallel or perpendicular to the field plane.



If the shape of the goalposts is elliptical (viewed from above), the longest axis must be perpendicular to the goal line. The longest axis of the crossbar must be parallel to the field plane.



If the shape of the goalposts is rectangular (viewed from above), the longest side must be perpendicular to the goal line. The longest side of the crossbar must be parallel to the field plane.



Both goalposts and the crossbar have the same width and depth, which do not exceed 12 cm (5 ins). The goal lines must be of the same width as the goalposts and the crossbar. Nets may be attached to the goals and the ground behind the goal, provided

that they are properly supported and do not interfere with the goalkeeper. The goalposts and crossbars must be white.

3.1.10 Safety

Goals must be anchored securely to the ground. Portable goals may only be used if they satisfy this requirement.

The field of play

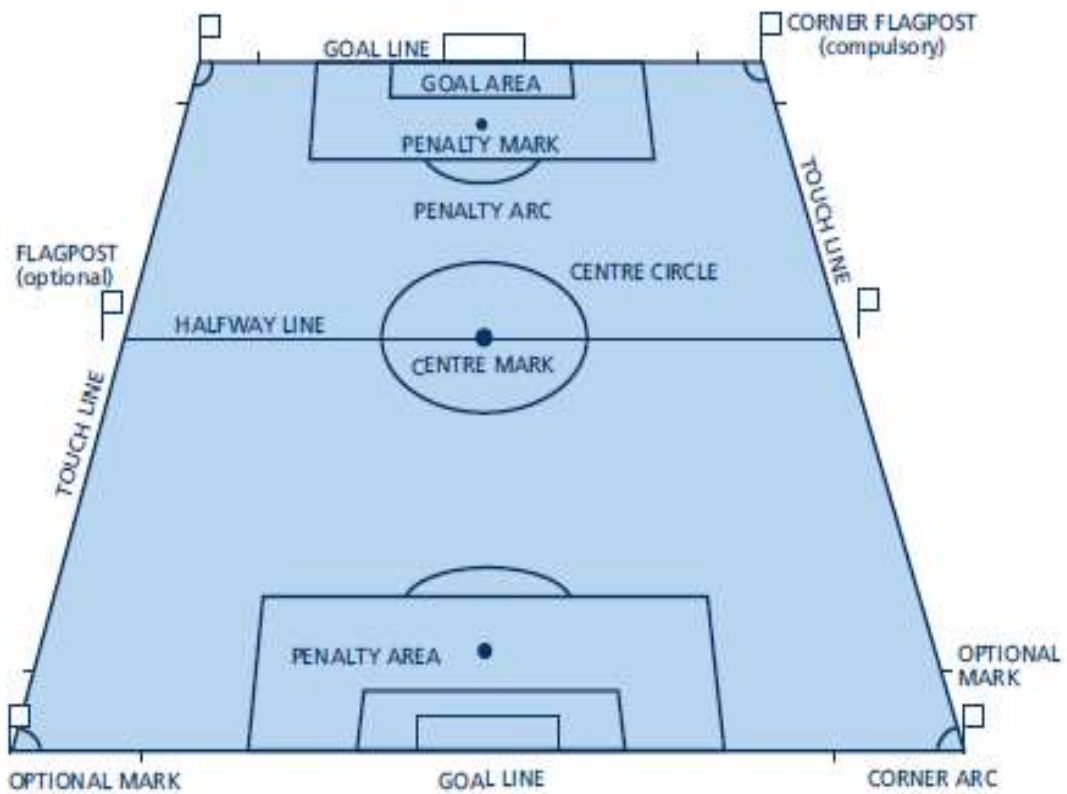

Corner flagpost

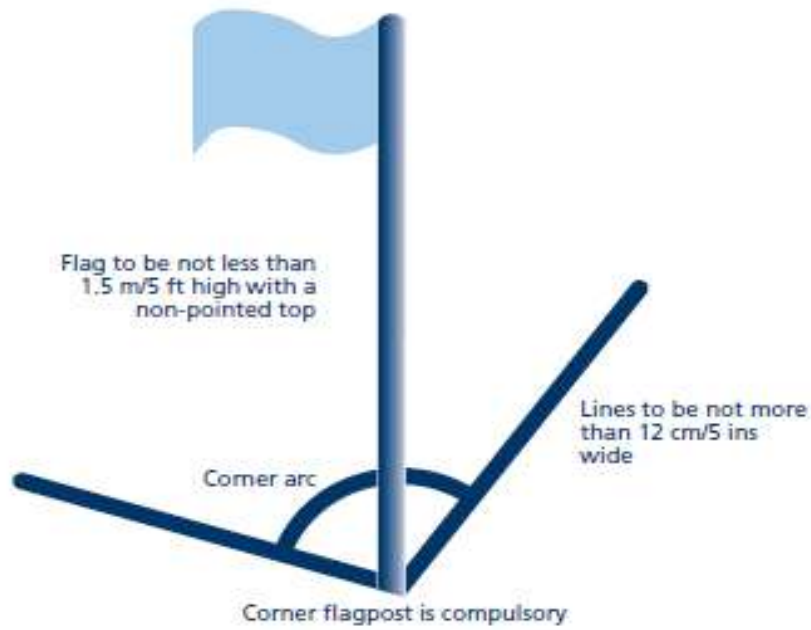

Metric measurements

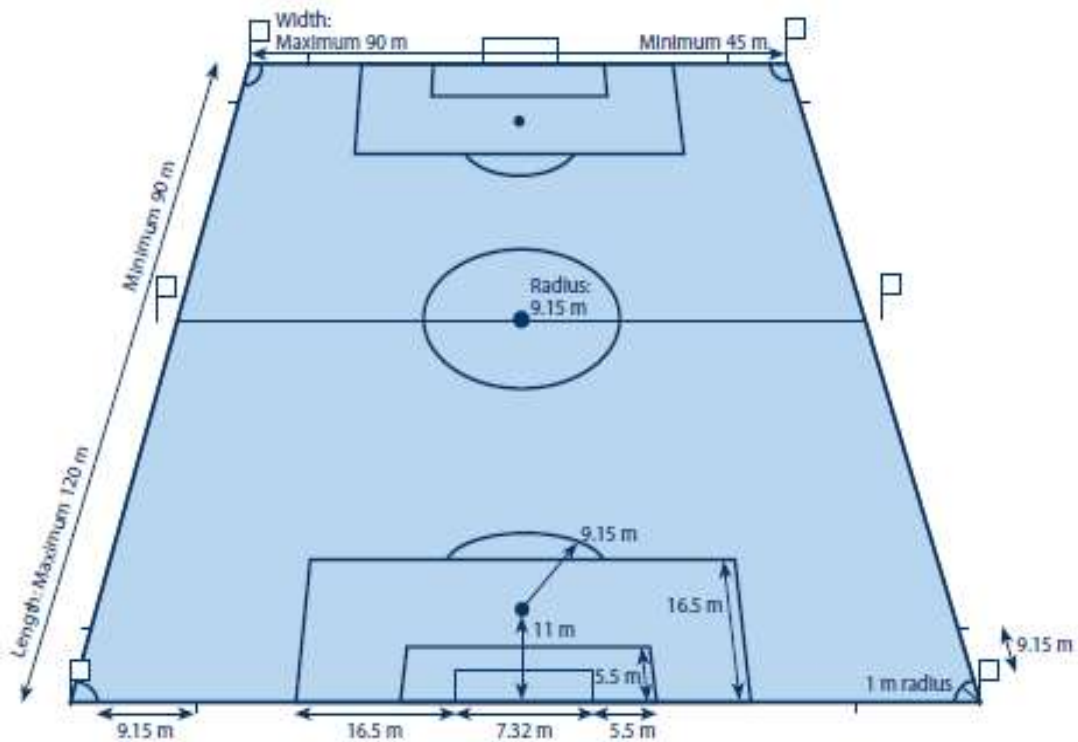

NOTE:

Modifications Field of Play

Subject to the agreement of the member association concerned and provided the principles of FIFA Laws OF THE GAME are maintained, the Laws may be modified in their application for matches for players of under 16 years of age, for women footballers, for veteran footballers (over 35 years of age) and for players with disabilities.

Any or all of the following modifications are permissible:

- Size of the field of play
- Size, weight and material of the ball
- Width between the goalposts and height of the crossbar from the ground
- Duration of the periods of play
- Substitutions

Further modifications are only allowed with the consent of the International Football Association Board.

3.2 Recommended dimensions (Compiled from



3.2.1 Playing field: length: 105m, width: 68m

- For all matches at the top professional level and where major international and domestic games are played, the playing field should have dimensions of 105m x 68m. These dimensions are obligatory for the FIFA World Cup and the final competitions in the confederations' championships. The playing field should have the precise markings illustrated.
- Other matches can be played on a playing field with different dimensions and the Laws of the Game stipulate the maximum and minimum dimensions. However it is strongly recommended that new stadiums have a 105m x 68m playing field.

3.2.2 Auxiliary area

Additional flat areas are required beside the playing field, ideally behind each goal line, where players can warm up. This area should also allow for the circulation of assistant referees, ball

boys and girls, medical staff, security staff and the media. It is recommended that this be a minimum of 8.5m on the sides and 10m on the ends.

This results in an overall playing field and auxiliary area dimension of:

length: 125m, width: 85m.

3.2.3 Grass area

In this area, a minimum of 5m on the sides or touch lines and 5m behind the goal lines, reducing at an angle to 3m near the corner flags (see diagram below), must be of the same surface material as the playing field (grass or artificial turf).

The remainder of the auxiliary area can be either of the same surface material as the playing field or it can be a concrete-type surface material which facilitates the movement of service and security vehicles and ambulances. Any part of this additional auxiliary area that will be used as a warm-up area should have the same surface as the playing field. However, with grass fields, artificial turf of the highest quality could be used.

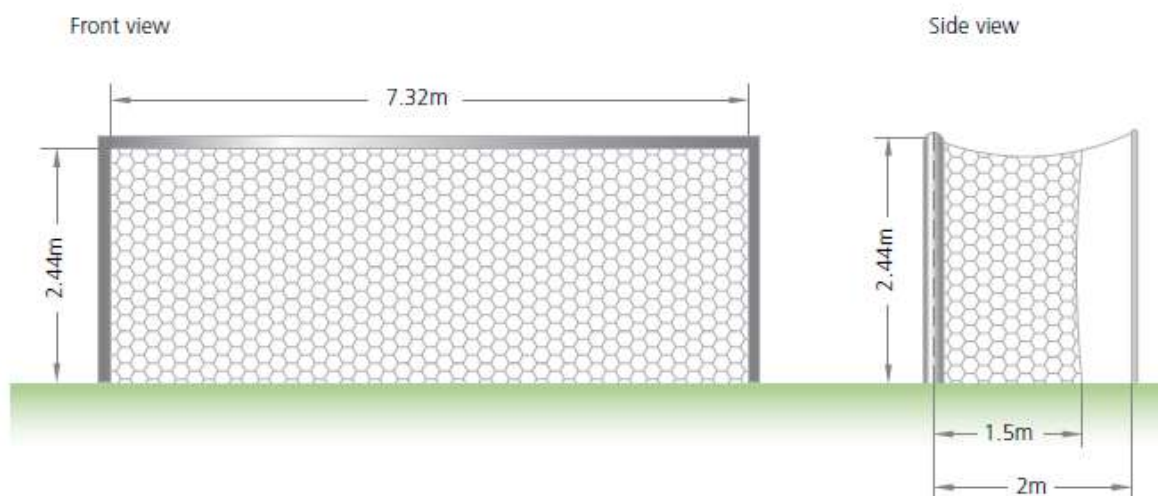

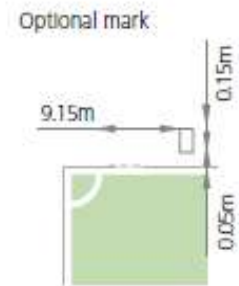
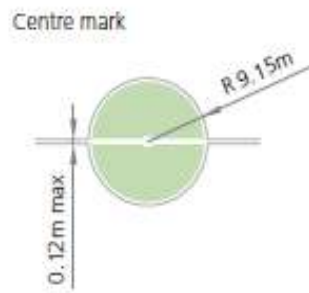
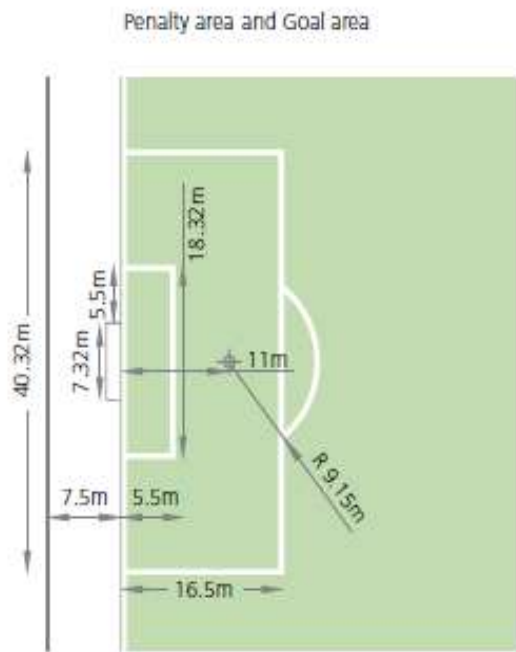

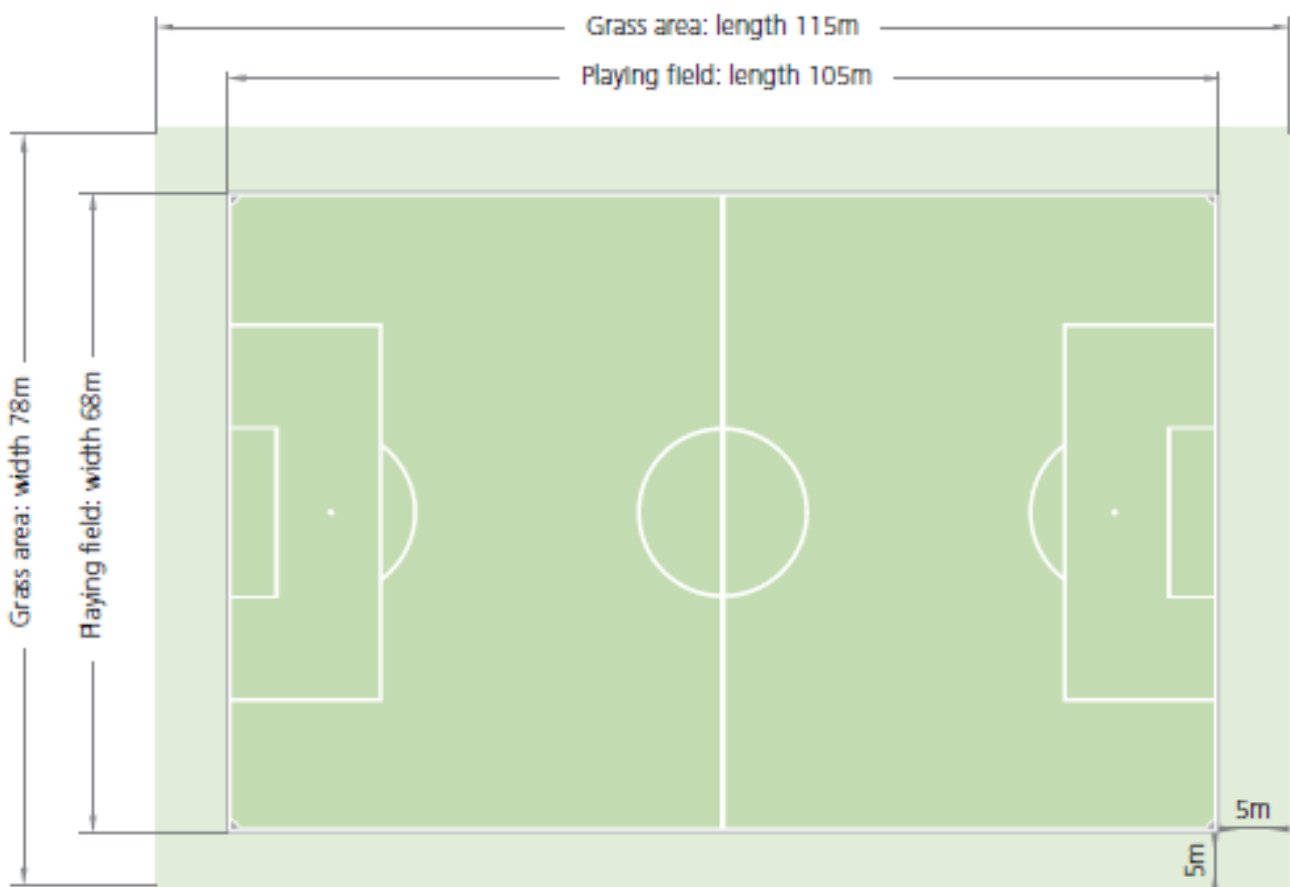
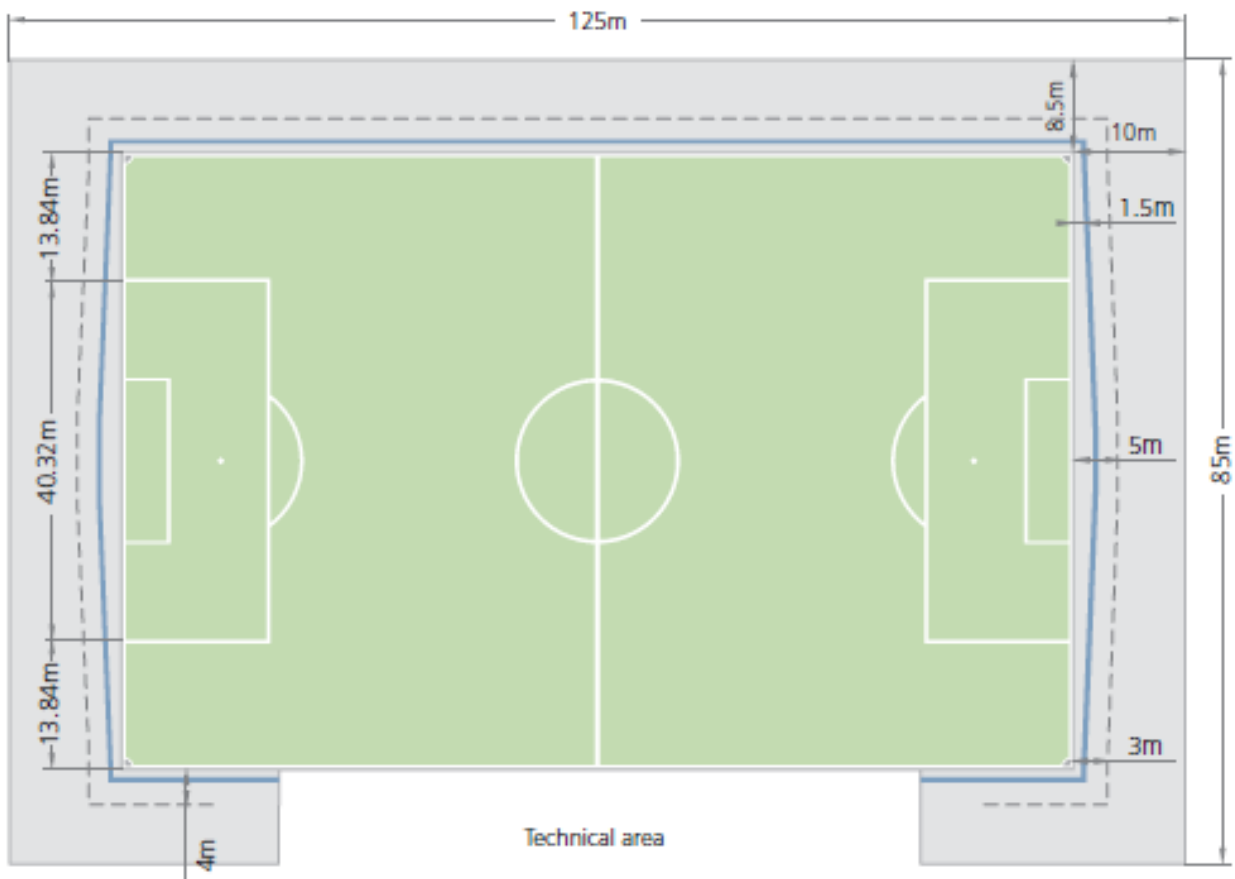

3.2.4 Dangers and obstructions

The playing field and auxiliary area should be free of any impediment or obstruction (e.g. sprinkler heads, field marking material, etc.) that would constitute a danger to players or others whose purpose takes them on to the area described.

Particular attention should be paid to the four corners of the playing field, to ensure that players have enough space to take corner kicks without having their run-up unduly restricted.

Goal nets should not be suspended by any kind of metal frame or “elbow” but should be suspended by the method illustrated (see diagram above), as this does not constitute a danger to players. If pins of any kind are used to fasten the nets to the ground they must not protrude above ground level.

3.3 ARTIFICIAL FOOTBALL TURF

3.3.1 Introduction

The development of artificial grass surfaces (designated „Football Turf“ by FIFA) that replicate the playing qualities of good quality natural grass has led to the rapid acceptance of the surfaces by the football world and an ever increasing expansion of the market. Manufacturers are now producing surfaces which have been found to provide an ideal solution to those parts of the world where climate or resources make the provision of good quality natural grass pitches difficult or impossible. Likewise the development of Football Turfs has provided a potential solution to facility operators wishing to maximize the use of their facilities through community use and those struggling with stadium microclimates that make the maintenance and growth of natural grass difficult.

Artificial turf today has become an acceptable playing surface for football as its development has produced a turf carpet that is especially designed for the sport. Artificial playing surfaces are now available that enable footballers to play both dynamically and safely.

The advantages of an artificial turf playing surface are numerous. Artificial turf makes it possible to always have a green playing surface. Playing on an artificial turf carpet requires players to adapt to the surface but the evenness of the playing surface makes for a quick, precise game in which both technical and physical players stand an equal chance.

In addition, artificial turf pitches can be used much more than natural pitches, increasing utilization of both the pitch and the facility. Artificial turf pitches do not suffer damage due to inclement weather (e.g. rain, snow), whereas these elements can significantly affect the use

of natural pitches. Regular maintenance, which is critical to keep artificial turf pitches in top shape, is less expensive than maintaining a quality natural turf pitch.

To ensure these new forms of playing surface replicate the playing qualities of good quality natural grass; provide a playing environment that will not increase the risk of injury to players; are of adequate durability (providing they are adequately maintained) FIFA developed its FIFA Quality Concept for Artificial Turf. Launched in 2001 the Quality Concept is a rigorous test programme for Football Turf that assesses the ball surface interaction, player surface interaction and durability of products and allows successful manufacturers to enter into a licensing programme for the use of the prestigious FIFA RECOMMENDED marks.

Following the decision of the International Football Association Board in July 2004 to introduce artificial surfaces into the Laws of The Game the FIFA Quality Concept has been further developed by introducing two categories of performance. FIFA Recommended Two Star is the professional category and has been established to ensure fields meeting it replicate the playing qualities of the best quality natural turf pitches. This category is intended for clubs and national federation teams wishing to play competitive matches subject to the relevant competition rules allowing the use of Football Turf or undertake training on Football Turfs. The FIFA Recommended One Star category has slightly wider bands of acceptability and is primarily aimed at organizations wishing to provide facilities for training and community use, although fields meeting this category of performance may also be used for competitive play (subject to the relevant competition rules).

The laboratory test programme that a Football Turf must satisfy as part of the FIFA Quality Concept includes a programme of simulated use to assess the ability of a surface to perform for a period of time. The degree of simulated use undertaken on FIFA Two Star products is designed to replicate low to moderate levels of use often found on football specific stadium fields; whilst the degree of simulated use undertaken on FIFA One Star products is designed to replicate the higher levels of use found on training and community fields. However, that experience has shown fields subjected to very high intensity use may not be able to retain the demanding performance criteria of the FIFA Quality Concept for the life of the playing surface. Failure to undertake adequate maintenance will also reduce the period of time a field may satisfy the requirements of the FIFA Quality Concept.

3.4 Field certification

The FIFA Quality Concept is the certification of a particular field that has been found to fully meet the requirements of the Quality Concept. It is not the approval of products. To gain such certification a FIFA licensee needs to undertake two phases of testing and operate a

programme of factory quality control that shall be open to third party attestation as considered appropriate by FIFA.

The phases of testing are described below.

3.4.1 Stage 1/3 - laboratory testing

- A potential Licensee (Manufacturer) or existing Licensee will submit the appropriate samples and the Laboratory Test Form to a FIFA accredited laboratory.
- The FIFA accredited laboratory will undertake all the statutory tests laid out in the FIFA Quality Concept – Handbook of requirements. If the sample submitted has fulfilled all the requirements a Test Report will be submitted to FIFA confirming that the potential Licensee's product has met the requirements of the FQC Laboratory Test Procedure.
- On request the (potential) Licensee will be informed by FIFA that the Licensee's Product has met the requirements of the FQC Laboratory Test Procedure and the Licensee can progress with the installation of fields for potential certification (subject to completion of the license the contract between FIFA and the Licensee).

3.4.2 Stage 2/3 - initial field assessment

- Following construction of a field the Licensee or facility owner will arrange for it to be tested by a FIFA Field Test Institute. The Test Institute appointed to undertake the field test shall not have been involved in the design, specification or procurement of the field. In advance of the field test the Licensee will inform FIFA of the intention to have the field tested, the Test Institute appointed to undertake the field test and the proposed date of test. FIFA will issue a unique Field Test Report Number to the Licensee and Test Institute.
- The field shall be fully tested in accordance with the procedures specified in Table below
- Samples of the artificial grass and any infill used to construct the field shall be taken from site by the Test Laboratory and tested to ensure they are of the same specification as those submitted for the initial laboratory type approval
- The results of the field and quality control tests will be entered onto a FIFA Field Test Report by the Test Laboratory which shall be sent to FIFA for review.
- The Laws of the Game allow international matches to be played on fields with several sets of lines. The IFAB ruling on Law 1 states: “Where artificial surfaces are used, other lines are permitted provided that they are of a different colour and clearly distinguishable from the lines used for football.”

□ The test institute shall take note of any additional markings (logos, writing, adverts) other than those specified in the Laws of the Game. As the professional standard, no FIFA 2 Star installation shall have any additional marking other than those accounted for in the Laws of the Game. FIFA 1 Star installations lose their eligibility to host competitive matches in accordance with the Laws of the Game by the presence of marks (logos etc.) on the field.

3.4.3 Stage 3 /3 – Field certification

If the field satisfies all aspects of the FIFA Quality Concept FIFA will grant the appropriate FQC star rating to the Licensee with a copy to the field owner/operator.

Note: Only fields surfaced with Football Turfs that have been laboratory tested (Stage 1) in advance of the field test (Stage 2) will be certified.

3.4.4 Eligibility for international competitions:

In order for international competitive matches to be carried out on any football field, they must meet the requirements of the respective sections in the Laws of the Game. This implies compatibility with the requirements regarding line marking and the absence of other marks on the field as well as the field dimensions.

3.5 Period of field certification

FIFA Recommended Two Star certification is valid for twelve months unless:

- the field is subsequently found to no longer satisfy all the aspects of the FIFA Quality Concept Two Star category
or
- the Football Turf is replaced.

FIFA Recommended One Star certification is valid for four years unless:

- the field is subsequently found to no longer satisfy all the aspects of the FIFA Quality Concept One Star category
or
- the Football Turf is replaced.

Note: If national competition rules or other requirements require field re-tests at more frequent intervals this is permitted.

3.5 Use of existing shock pads / elastic layers

If an existing artificial turf pitch is to be converted to Football Turf or an existing Football Turf surface is to be replaced, any existing shockpad or elastic layer may be incorporated into the new surfacing system provided:

- the mean shock absorption of the existing shockpad is between 90% and 110% of the shock absorption value declared by the manufacturer when the Football Turf system was initially type approved;
- the mean deformation of the existing shockpad is + 2mm of the deformation declared by the manufacturer when the Football Turf system was initially type approved;
- the water permeability of the shockpad is greater than 180mm/h .

The installed shockpad shall be tested for each property detailed above in the positions detailed in the FIFA Handbook of Tests Methods for Football Turf by a FIFA Field Institute. Tests shall be made no sooner than 12 months before the initial field test after resurfacing. The results of the shockpad tests shall be appended to the FIFA Field Test Report and issued to FIFA following the initial field test

Table 1 – Laboratory test requirements

Property	Test Method	Test conditions			Requirements	
		Preparation	Temperature	Condition	FIFA Recommended Two Star	FIFA Recommended One Star
Vertical ball rebound	FIFA 01 & FIFA 09	Pre-conditioning	23°C	Dry	0.60m - 0.85m	0.60m - 1.0m
				Wet		
		Simulated Wear – 5,200 cycles		Dry	0.60m - 0.85m	N/A
		Simulated Wear – 20,200 cycles		Dry	N/A	0.60m - 1.0m
Angle ball rebound	FIFA 02	Pre-conditioning	23°C	Dry	45% - 60%	45% - 70%
				Wet	45% - 80%	
Ball roll	FIFA 03	Pre-conditioning	23°C	Dry	4m - 8m	4m - 10m
				Wet		
Shock Absorption	FIFA 04a & FIFA 09	Pre-conditioning	23°C	Dry	60% - 70%	55% - 70%
				Wet		
		Simulated Wear – 5,200 cycles		Dry	60% - 70%	N/A
		Simulated Wear – 20,200 cycles		Dry	N/A	55% - 70%
		Pre-conditioning	40°C	Dry	60% - 70%	55% - 70%
	FIFA 04a 1 st impact	-	-5°C	Frozen	60% - 70%	55% - 70%

Property	Test Method	Test conditions			Requirements	
		Preparation	Temperature	Condition	FIFA Recommended Two Star	FIFA Recommended One Star ³
Vertical Deformation	FIFA 05a & FIFA 09	Pre-conditioning	23°C	Dry	4mm – 10mm	4mm – 11mm
		Pre-conditioning		Wet		
		Simulated Wear – 5,200 cycles		Dry	4mm – 10mm	N/A
		Simulated Wear – 20,200 cycles		Dry	N/A	4mm – 11mm
Rotational Resistance	FIFA 06 & FIFA 09	Pre-conditioning	23°C	Dry	30Nm - 45Nm	25Nm - 50Nm
		Pre-conditioning		Wet		
		Simulated Wear – 5,200 cycles		Dry	30Nm - 45Nm	N/A
		Simulated Wear – 20,200 cycles		Dry	N/A	25Nm - 50Nm

Property	Test Method	Test conditions			Requirement	
		Preparation	Temperature	Condition	FIFA Recommended Two Star	FIFA Recommended One Star ³
Linear Friction - Stud Deceleration Value	FIFA 07	Pre-conditioning	23°C	Dry	3.0g - 5.5 g	3.0g - 6.0 g
				Wet		
Linear Friction - Stud Slide Value	FIFA 07	Pre-conditioning	23°C	Dry	130 - 210	120 – 220
				Wet		
Skin / surface friction	FIFA 08	Pre-conditioning	23°C	Dry	0.35 - 0.75	0.35 - 0.75
Skin abrasion	FIFA 08	Pre-conditioning	23°C	Dry	± 30%	± 30%

Artificial Weathering (FIFA 10)						
Component	Property & test method			Requirement		
				FIFA Recommended Two Star	FIFA Recommended One Star	
Artificial turf	Colour change	EN ISO 20105-A02		≥ Grey scale 3		
Pile yarn (s)	Tensile strength	EN 13864		Percentage change from unaged to be no more than 50%		
Polymeric infill	Colour change	EN ISO 20105-A02		≥ Grey scale 3		
Joint strength: stitched seams	Joint strength – unaged	EN 12228 Method 1		1000N/100mm		
	Joint strength - after immersion in hot water	EN 13744 & EN 12228 Method 1				
Joint strength: Bonded seams	Joint strength – unaged	EN 12228 Method 2		25N/100mm		
	Joint strength - after immersion in hot water	EN 13744 & EN 12228 Method 2				

Property	Test Method	Condition	Requirement	
			FIFA Recommended Two Star	FIFA Recommended One Star
Tuft withdrawal	ISO 4919	Unaged	≥30N	≥30N
	EN 13744 & ISO 4919	After immersion in hot water	≥30N	≥30N
Tensile strength of shockpads and e-layers (if supplied as part of system)	EN 12230	Unaged	0.15Mpa	0.15Mpa
Water permeability ¹ - using a single ring infiltrometer in which the artificial turf carpet is sealed prior to infilling and testing	EN 12616	Unaged	> 180mm/h ⁽²⁾	> 180mm/h ⁽²⁾

1 Not applicable to surfaces designed specifically for indoor use

2 To ensure adequate drainage of a field all individual elements of the football turf should satisfy this requirement. Any value above 2000mm/h shall be recorded as ">2000mm/h"

Component	Characteristic	Test method	Permitted variation between laboratory component and manufacture's declaration
Stabilising Infill (if supplied as part of system)	Particle size	EN 933 - Part 1	≤ ± 20%
	Particle shape	prEN 14955	Similar shape
	Bulk density	EN 1097-3	≤ ± 15%
Shockpads / e-layers (if supplied as part of system)	Shock Absorption	EN 14808	≤ ± 5% Force Reduction
	Thickness	EN 1969	≥ 90% of manufacturer's declaration
Unbound sub-bases (if tested as part of system)	Composition	-	Same composition
	Particle size range (attach particle size grading to test report)	EN 933 - Part 1	≤ ± 20%
	Particle shape	prEN 14955	Similar shape

Table 2 – Product identification tests

Component	Characteristic	Test method	Permitted variation between laboratory component and manufacture's declaration
Artificial turf	Total mass per unit area	ISO 8543	≤ ± 10%
	Tufts per unit area Knots per unit area (woven carpets) ¹	ISO 1763	≤ ± 10%
	Tuft withdrawal force ²	ISO 4919	≥ 90% of manufacturer's declaration
	Pile length above backing	ISO 2549	≤ ± 5%
	Total pile weight Pile weight above backing (woven carpets) ³	ISO 8543	≤ ± 10%
	Water permeability	EN 12616 using a single ring infiltrometer	≥180mm/h ⁴
Pile yarn(s)	Pile yarn characterisation	ISO 11357-3	Same polymer
	Pile dtex	See Note 1 below	≤ ± 10%
Performance infill (if supplied as part of system)	Particle size	EN 933 - Part 1	≤ ± 20%
	Particle shape	prEN 14955	Similar shape
	Bulk density	EN 1097-3	≤ ± 15%
	Composition	TGA	≤ ± 15% relative

3.6 Maintenance equipment

For a field to be certified under the FIFA Quality Concept for Football Turf the facility operator shall ensure that all the equipment specified by the surface manufacturer for the installed Football Turf product is available to maintain the field in accordance with the manufacturer's instructions. This may either be achieved by the facility operator purchasing the equipment or entering a service agreement with a specialist maintenance contractor or a combination of both. In the case of maintenance being outsourced, the manufacturer shall present written evidence of such an agreement to maintain the field.

Maintenance equipment on site must at least include a tractor unit, either a drag brush or drag mat, additional infill to top up the field and a ball roll ramp. If this is not the case, the test institute shall note this on the field test report and indicate the field as failed.

The facility operator shall ensure all required maintenance equipment is available for inspection by the test institute during the field test.

3.7 Sprinklers

FIFA do not endorse the use of sprinklers within the playing area of a football field. However, FIFA does acknowledge that occasionally sprinkler systems have to be installed within the playing area because, primarily due to a lack of water pressure available to project water from outside of the play area onto the central portion of the field; such systems have been installed in both natural and artificial turf football fields.

One of the primary aims of the FIFA Quality Concept for Football Turf is to take into consideration the comfort and safety of players. Therefore where a sprinkler system has been installed within the playing area there will be an additional test requirement to check that the sprinklers do not present an additional hazard to the players. The Field Test Institute will undertake Shock Absorbency and Vertical Deformation evaluation, in accordance with this manual, on two separate sprinklers (either side of the field). The values obtained must be within the requirements for the particular performance level that the field has been constructed to meet. Neither FIFA nor the field test institute shall be liable for any damage occurring to the sprinklers as a result of these tests. In requesting/allowing a FIFA field test the facility operator is deemed to have accepted this condition of test.

3.8 Natural grass playing fields

3.8.1 Development

Football has traditionally been played on natural grass, which has a series of needs, as it is a living plant and changes with the seasons. Climatic conditions also vary in different parts of the world. For example, there are some environments in which grass grows all year round and others in which the seasons affect its condition. Natural grass requires light and nutrients; it must be tended and maintained and it also needs time. Particularly in stadiums, today's playing surfaces are no longer sown but are laid with instant turf. Although this saves time and is costly, the needs of the grass remain the same.

Natural grass also struggles with modern stadium architecture, which deprives it of light and air. The grass also has to contend with the other purposes for which the stadium is used. With natural grass, the laws of nature cannot be circumvented.

Sports turf is now extensively cultivated and delivered as rolled or flat sod. The transplanted turf must be compatible with the substrate and the growth time must be monitored. The grass is susceptible to disease, wear and tear and regeneration times. Having qualified staff to take care of the grass is therefore of great importance, otherwise nature will take its own course.

Instant turf is extensively cultivated and transported to the building site in lorries and is laid with suitable machinery. The turf must have the same soil value as the underlay and be laid at the appropriate moment. Watering is necessary for germination and growth, so automatic or manual watering is therefore essential. The laying of turf of different densities is usual practice these days, as it facilitates use in a shorter period of time and means that the grass is already green from the start.

3.8.2 Drainage

Local conditions must be taken into account for calculating the drainage, which consists of a system of pipes laid in trenches and clad in permeable, round gravel. The pipes are laid at an incline and enclosed in shafts (system monitor).

3.8.3 Edging

Depending on the terrain, kerb stones or drainage trenches are used particularly when there is an adjoining running track that needs to be drained. The transition from grass to running track must be even (for corners).

3.8.4 Seed

The choice of seed or seedling for the natural turf depends to a large degree on the location.

3.8.5 Watering

As a rule, automatic watering apparatus is installed in the stadiums. Watering can be reduced in environments with favourable climatic conditions. The sprinklers must be installed outside the playing surface

3.9 ARTIFICIAL LIGHTING

3.9.1 Overview

The primary goal of the event lighting system is to illuminate the event to digital video quality for the media without creating nuisance glare for the players/officials and adding spill light/glare to the spectators and surrounding environment. Permanent lighting, temporary lighting and a combination of both systems should be considered.

Special care should be taken to limit the spill light and glare off the field, both inside and outside the stadium.

The players and officials must be able to perform to their fullest ability within an illuminated environment that enhances play.

The principal goal of the lighting system is to ensure symmetrical lighting for both touch line and goal line conditions. Both fixed and field cameras can be added without affecting the digital video quality.

3.9.2 Mounting height of light fittings

The mounting height of the light fittings is critical to the success of the sports lighting system. The mounting height geometry for sideline head frames and poles is 25 degrees above the horizon, starting from the middle of the pitch and looking back towards the stadium seating bowl. The head frame and light structure may exceed this 25- degree minimum guideline but it may not exceed 45 degrees.

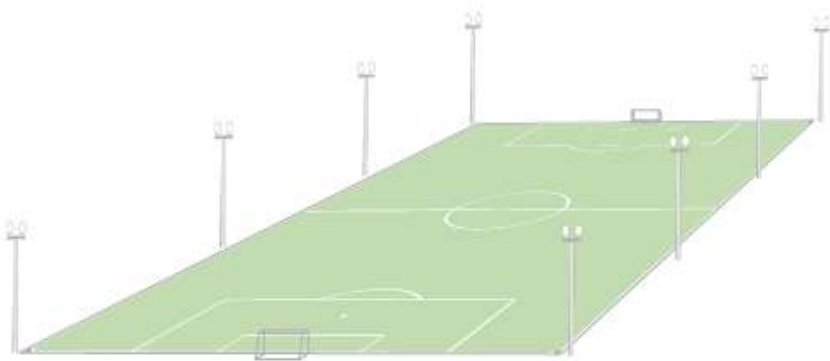
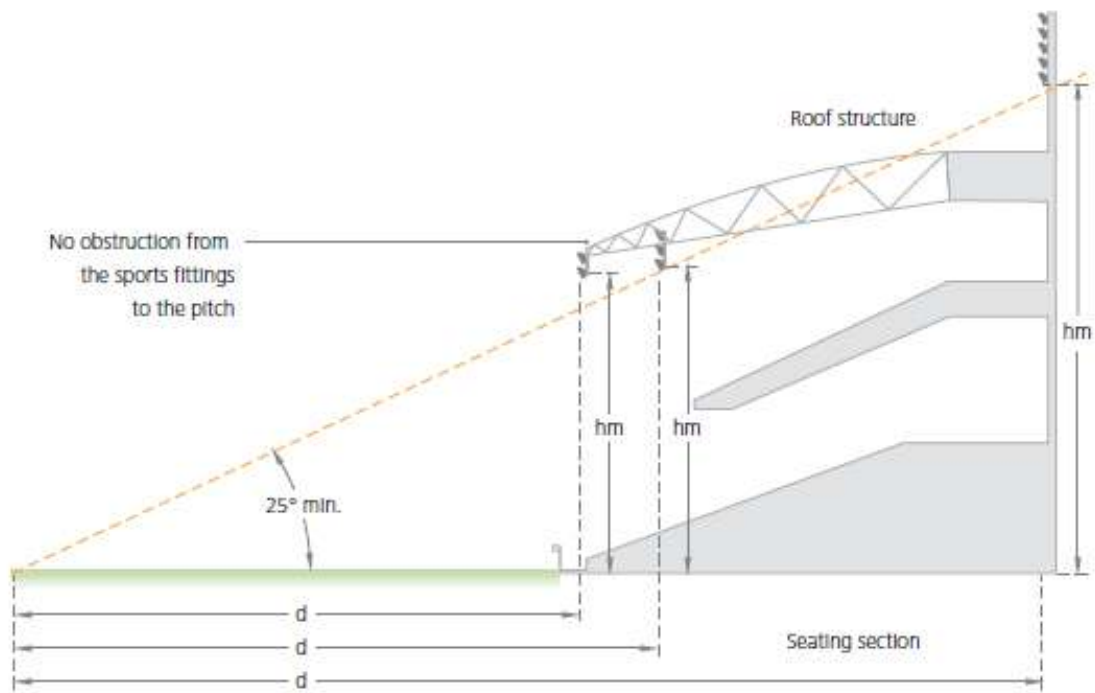

Diagram 9h:
Installation planning
(non-televised)

Class III
National game

Summary of lighting specifications for non-televised events

The following table is a summary of the criteria to be considered for non-televised events. It sets out the recommendations for horizontal illuminance, uniformity and the properties of lamps, for each level of activity.

Lighting specifications for non-televised events

Activity level	Horizontal illuminance	Uniformity	Lamp colour temperature	Lamp colour rendering
Class	Eh ave (lux)	U2	Tk	Ra
Class III National games	750	0.7	> 4,000	≥ 65
Class II Leagues and clubs	500	0.6	> 4,000	≥ 65
Class I Training and recreation	200	0.5	> 4,000	≥ 65

Notes:

- All illuminance values indicated are maintained values.
- A maintenance factor of 0.70 is recommended. Initial values will therefore be approximately 1.4 times those indicated above.
- Illuminance uniformity shall not exceed than 30% every 10 metres.
- Primary player view angles must be free of direct glare. This glare rating is satisfied when the player view angles are satisfied.

Summary of lighting specifications for televised events

The following table is a summary of the criteria to be considered for televised events. It sets out the recommendations for vertical and horizontal illuminance, uniformity and the colour properties of lamps, for each class of activity.

Lighting specifications for televised events

		Vertical illuminance			Horizontal illuminance			Properties of lamps	
		Ev cam ave	Uniformity		Eh ave	Uniformity		Colour temperature	Colour rendering
Class	Calculation towards	Lux	U1	U2	Lux	U1	U2	Tk	Ra
Class V International	Fixed camera	2,400	0.5	0.7	3,500	0.6	0.8	> 4,000	≥ 65
	Field camera (at pitch level)	1,800	0.4	0.65					
Class IV National	Fixed camera	2,000	0.5	0.65	2,500	0.6	0.8	> 4,000	≥ 65
	Field camera (at pitch level)	1,400	0.35	0.6					

Notes:

- Vertical illuminance refers to illuminance towards a fixed or field camera position.
- Vertical illuminance uniformity for field cameras can be evaluated on a camera-by-camera basis and variation from this standard will be considered.
- All illuminance values indicated are maintained values. A maintenance factor of 0.7 is recommended; therefore initial values will be approximately 1.4 times those indicated above.
- In all classes, the glare rating is $GR \leq 50$ for players on the pitch within the player primary view angle. This glare rating is satisfied when the player view angles are satisfied.
- Constant Illumination Lamp technology is acceptable and encouraged.

3.10 SPECIFICATIONS FOR SAI CENTRES

The natural grass football turf is about 60 percent cheaper than a synthetic turf but require continuous and expert maintenance along with expensive imported machinery/ equipment to keep it to an international standard. In heavy rainfall areas the natural grass field becomes literally unplayable. In contrast the synthetic turf surface remains cool, and playable. and maintenance cost is also less.

The major issue with synthetic football turf is that the initial cost is very high but the maintenance cost is much less compared to a natural grass field, Moreover natural grass surface gets damaged if field is extensively used by trainees

So If there are no budget constraints, the synthetic football turf may be provided in high rainfall areas and where football is played extensively and is popular so that football trainees can train throughout the year on a leveled green surface.